

PM Series - PH Type

Helical-Worm Gear Units

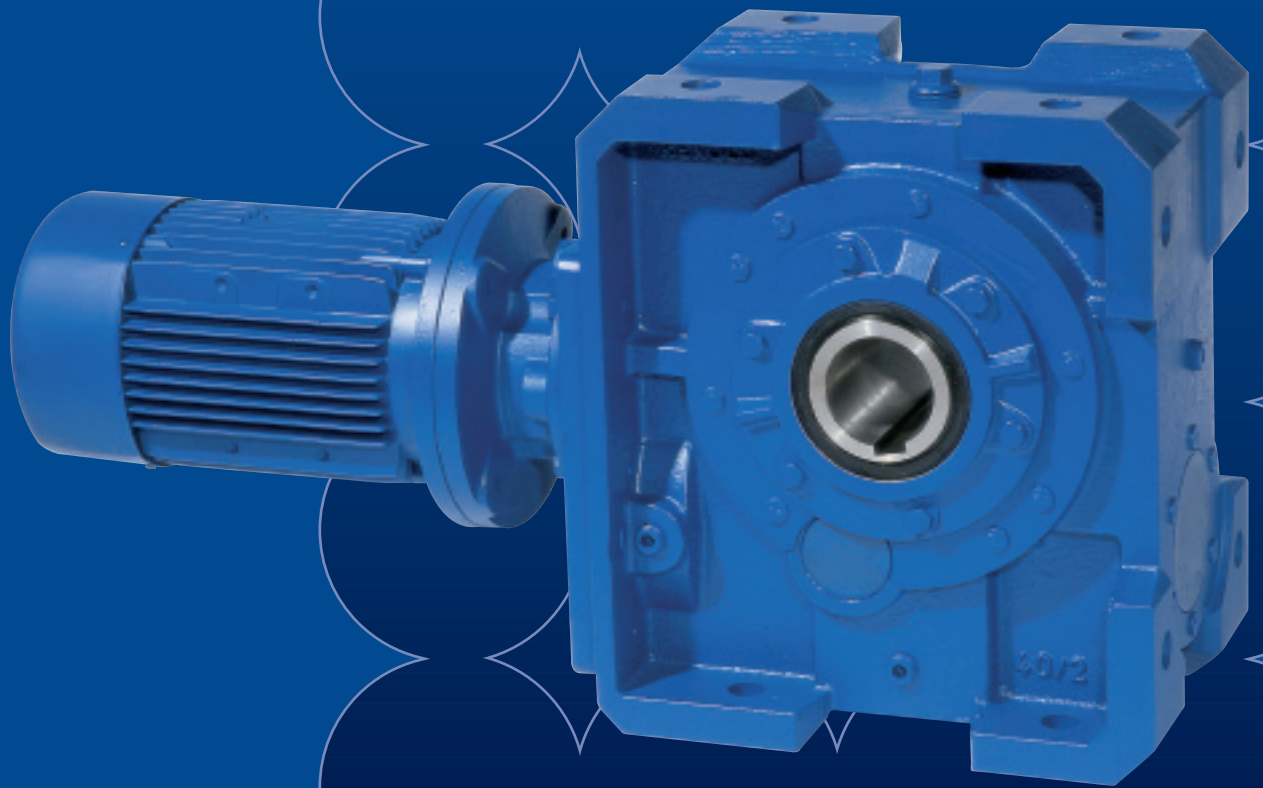

RENOLD
Superior Gear Technology

www.renold.com

RENOLD PM Series - PH Type Product Features

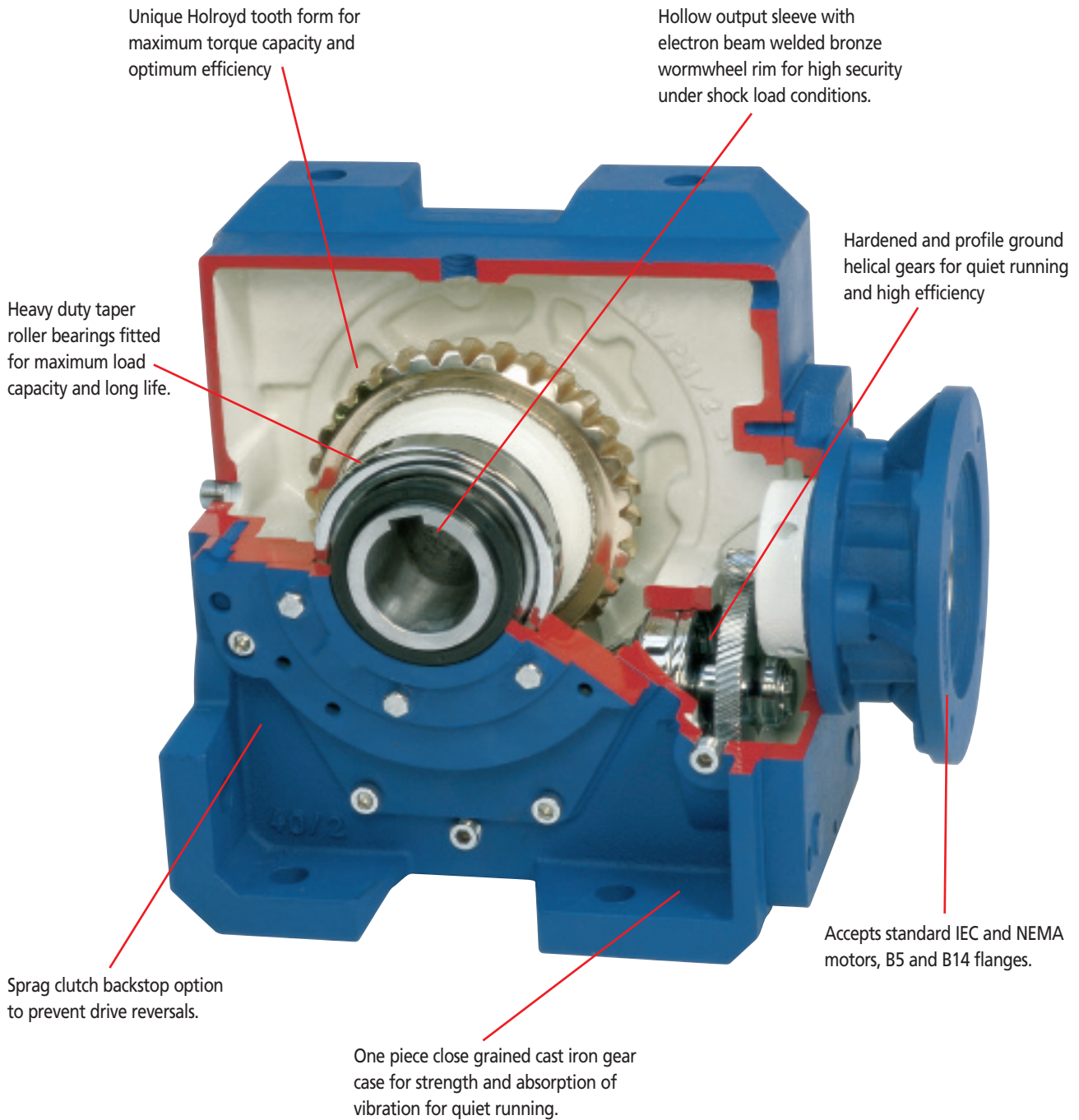

Applications:

- Conveyors
- Mining
- Timber
- Textiles
- Materials Handling
- Packaging Machinery
- Food Process Machinery
- Water Treatment
- Foundry equipment
- General Industrial Applications

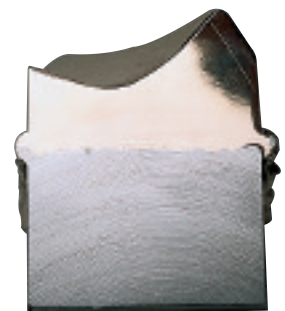

Section of electron beam welded wormwheel rim and centre showing the fusion of the bronze wormwheel rim onto the cast iron centre. This high security fit allows transmission of power under shock load conditions.

Contents

	Page No
PM Series - PH Type Unit Product Features	2
ATEX Approval Details	4
General Specification	5
Product Design Variations	6 - 7
Unit Mounting and Handing Details	8 - 9
Electric Motor Specifications	10 - 12
Ordering Designation Code	13
Inertia Values	14
Selection of PM Series - PH Type Unit	15 - 16
Load Classification by Application	17
Overhung and Thrust Loads	18
Motorised Unit - Selection Data	19 - 31
Motorised Unit - Dimensions	32 - 35
Speed Reducer Unit - Overhung and Axial Load Capacities	36
Speed Reducer Unit - Exact Ratio	37
Speed Reducer Unit - Selection Data	38 - 51
Speed Reducer Unit - Dimensions	52 - 54
Plug-in Output Shaft Dimensions	55
Torque Restraint Bracket	56
Shrink Disc	57
Torque Arm Assembly	58
Installation, Maintenance and Storage	59
Lubrication	60
Oil Capacities	61
Weights	62 - 63
Renold Worldwide Sales and Service	64 - 65

ATEX Approval Details

ATEX Approval

RENOLD Gears products for operating in potentially explosive atmospheres.

General

- **RENOLD** Gears units are classified as ATEX Group II Category 2 equipment, which embodies sufficient safeguards to be suitable for use in potentially explosive atmospheres for normal operation and for operation during an expected malfunction.
- It is essential that there is sufficient lubricant to prevent the gears and bearings running 'dry'. Gear units should be inspected daily for signs of oil leakage, overheating or noisy operation.
- Gear units should be cleaned at regular intervals depending on the operating conditions, to ensure that dust coatings never exceed 5mm. Plastic parts should be wiped clean with a damp cloth.
- Oil leaks should be dealt with as quickly as practical. Compound joint faces and shims should be cleaned and thread-locking sealant should be applied to bolts and plugs prior to re-assembly.

- The temperature of any external surfaces must not exceed the permitted maximum of 135°C (T4).
- Higher temperature class T3 is available dependant on unit mounting, ratio and gear type. For further details consult **RENOLD**.
- As a general rule, gear units should be mounted with their feet horizontal. For other mountings, particularly with shaft mounted units, consult **RENOLD** Gears.

WARNING: IF MOUNTING WITH VERTICAL INPUT OR OUTPUT SHAFTS, THE ATEX CERTIFICATION DOES NOT APPLY.

Unit Selection

- The gear unit selection procedures must include an additional reliability factor of 1.25 for mechanical ratings and 1.25 for thermal ratings.

ATEX Nameplate

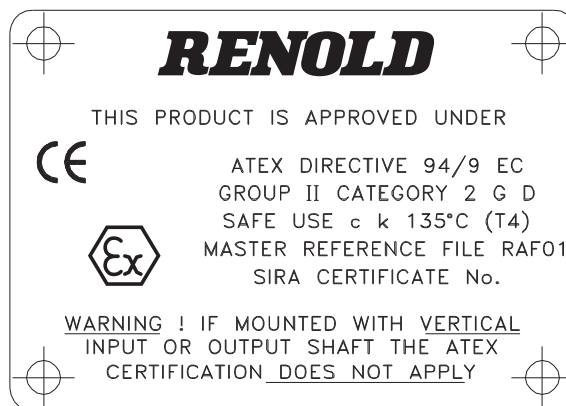

RENOLD PM Series - PH Type Product Specification

Gear Case

The gear cases are of close grained cast iron with all joints and bearing bores accurately machined to ensure oil tightness and precise gear location.

Gears

The first reduction stage helical gears are made from case hardened alloy steel with ground profiles to ensure smooth, quiet running with maximum life and efficiency.

The worm is integral with its shaft and manufactured from alloy steel, casehardened on the threads and ground and polished on the thread profiles.

The wormwheel rim is made from bronze complying with BS 1400 PB2-C (centrifugally cast) and secured to the cast iron centre by the electron beam welding process.

The Holroyd gear form used in the **RENOLD** PM Series gear units corresponds to British Standard recommendations but, in addition, has an exclusive feature which consists principally of an important modification to the worm threads and wheel teeth which confers additional valuable properties to gear performance. This ensures that our gears will run correctly and transmit true uniform angular velocity when running under all load conditions. The modification also gives a tapered oil entry gap between the teeth, which drags the lubricant between the surfaces and results in more efficient lubrication. Standard worm gears have right-hand threads but left-hand threads can be made to order.

Shafts

Standard shaft extensions are to metric dimensions, but imperial shaft extensions for units complying with BS3027: 1968 or to suit the requirements of the North American market are also available. The output Shaft is manufactured in carbon steel, but if required by applicational conditions, can be made from high tensile steel, in single or double extension.

Bearings

Standard metric taper/roller bearings are fitted throughout the **RENOLD** PM Series range of units in both single and double extension shaft options.

Oil Seals

Semi-dual lip oil seals are fitted to all hollow output shaft units.

Dry Well Feature

The **RENOLD** PM Series unit can be factory fitted with a 'dry-well' adaption at the output shaft to create a non oil leak unit. The output shaft bearing within the dry well is grease lubricated.

The non leak feature is particularly important on mixer drive applications in food and chemical plants where the unit shaft is vertically down.

Lubrication

Gear and bearings are positively lubricated by oil from the sump in the underdriven and overdriven versions at normal motor speeds. With the vertical type, grease lubrication is necessary to the wheeline bearings.

For lower speeds it may be necessary to consider grease lubrication of certain bearings and in this instance it is advisable to consult with Renolds Engineers. Full lubrication details can be found under the "Installation & Maintenance" section.

Backstop

Sprag clutch backstops can be fitted to all units to prevent unit run back when required.

Input Housing

When the **RENOLD** PM Series unit is supplied as a non-motorised unit i.e. for direct coupling or driven via a V-belt or chain drive, a high speed input shaft housing is fitted. This consists of a robust housing containing the input shaft which is supported in maintenance-free bearings.

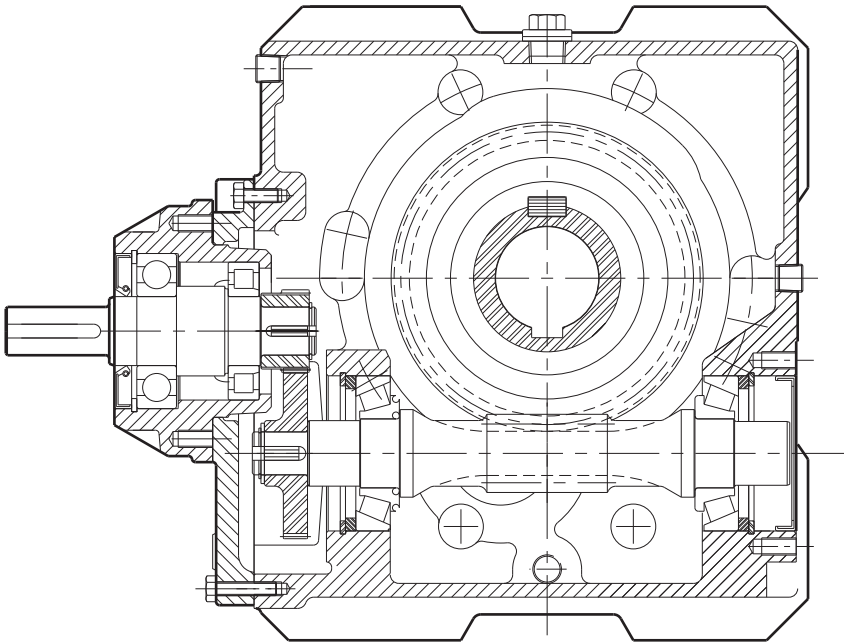

Hollow output shaft unit showing standard metric extension on input shaft adaptor

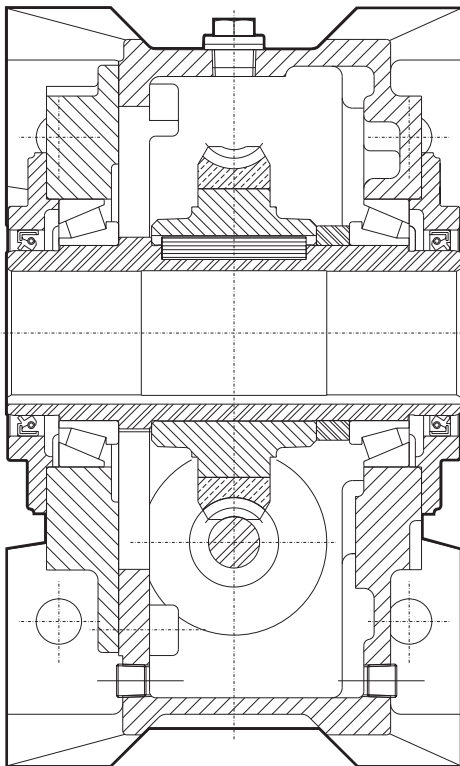

Standard hollow output shaft with semi dual lip oil seal for added oil retention

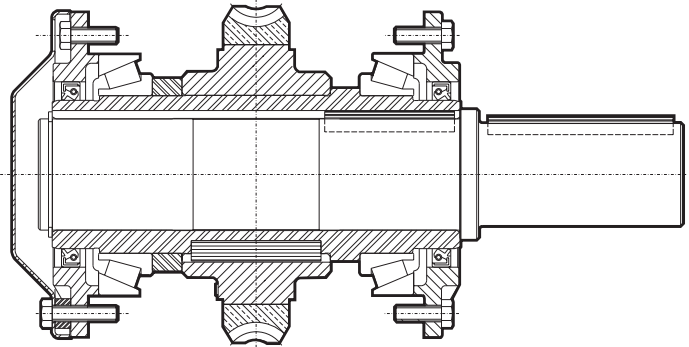

Standard plug-in output shaft. Single and double extension shafts are available with metric and American dimensions.

RENOLD PM Series PH Type - Product Design Variations

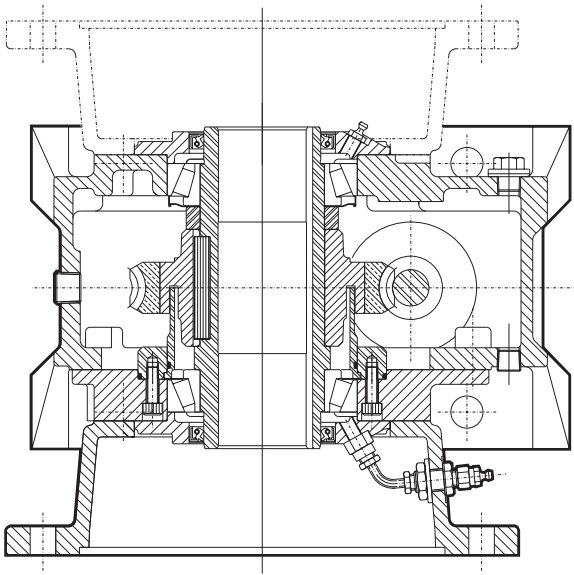

Unit fitted with output location flange and dry well adaptation at the output of the PM Series unit. The non leak feature is particularly important on mixer applications in the food and chemical Industry.

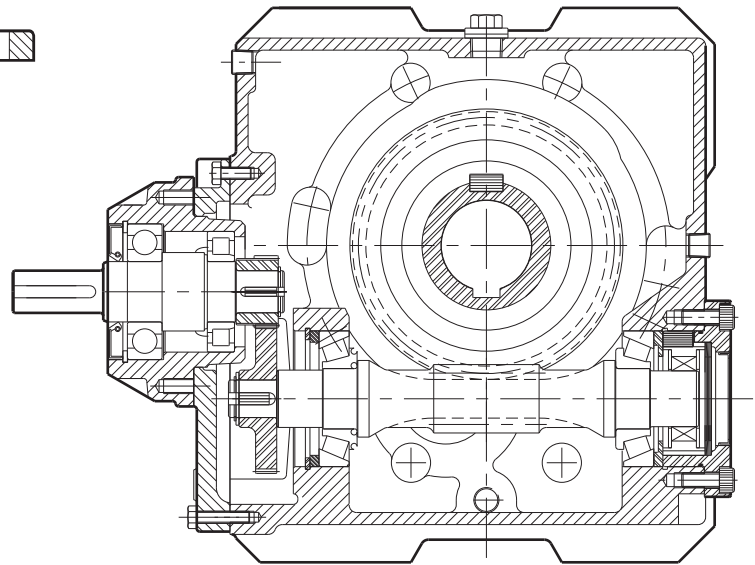

Sprag Clutch, anti run-back assembly fitted to the input shaft, to prevent unit run back. The Sprag Clutch can be supplied as a kit for retro fitting at any time.

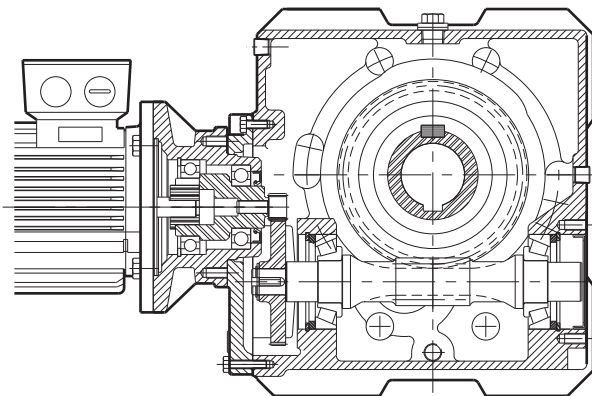

Motorised unit made to suit standard IEC and NEMA motors.

Underdriven

No Sprag backstop fitted.
Sprag backstop fitted.

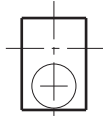

UA

UB

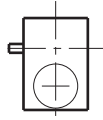

UC

UD

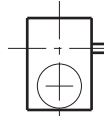

UE

UF

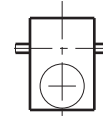

UG

UH

No Sprag backstop fitted.
Sprag backstop fitted.

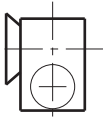

UJ

UK

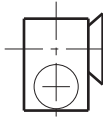

UL

UM

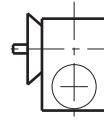

UN

UP

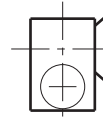

UQ

UR

No Sprag backstop fitted.
Sprag backstop fitted.

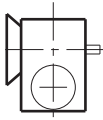

US

UT

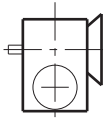

UU

UV

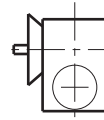

UW

UX

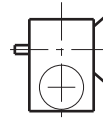

UY

UZ

Overdriven

No Sprag backstop fitted.
Sprag backstop fitted.

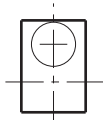

OA

OB

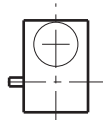

OC

OD

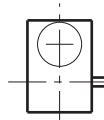

OE

OF

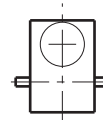

OG

OH

No Sprag backstop fitted.
Sprag backstop fitted.

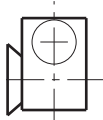

OJ

OK

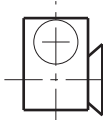

OL

OM

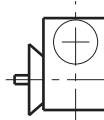

ON

OP

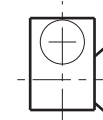

OQ

OR

No Sprag backstop fitted.
Sprag backstop fitted.

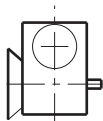

OS

OT

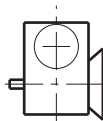

OU

OV

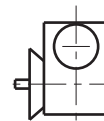

OW

OX

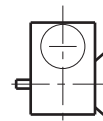

OY

OZ

RENOLD PM Series - PH Type - Mounting & Handing

Vertical

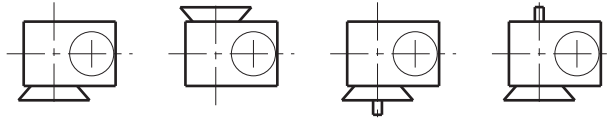

No Sprag backstop fitted.
Sprag backstop fitted.

VA
VB

VC
VD

VE
VF

VG
VH

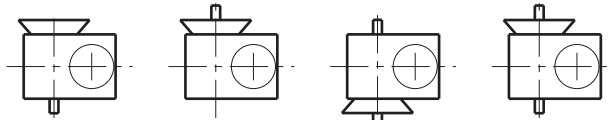

No Sprag backstop fitted.
Sprag backstop fitted.

VJ
VK

VL
VM

VN
VP

VQ
VR

Wall Mounting

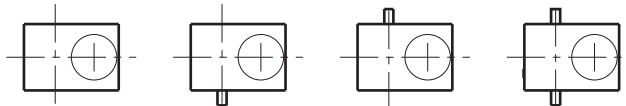

No Sprag backstop fitted.
Sprag backstop fitted.

WA
WB

WC
WD

WE
WF

WG
WH

PH Type with dry well sump (Factory Built)

Electric Motor Specification

4POLE/1500 RPM

DMA1 = aluminium series 1 DM1 = cast iron series 1 IEC-DIN			Rated Output Power PN kW	Full Load Current			Full-Load Speed nN min-1	Full-Load Power Factor cos	Full-Load Efficiency %	Locked Rotor Current La/LN	Locked Rotor Torque Ma/MN	Breakdown Torque Mk/MN	Moment of Inertia J kgm2	Nett Weight IM B3 m kg
				380 V IU A	400 V IN A	420 V IO A								
DMA1	80	K4	0.55	1.58	1.55	1.56	1365	0.79	64.7	4.0	1.8	2.1	0.001146	8.9
DMA1	80	G4	0.75	2.00	1.99	2.00	1345	0.80	67.9	4.0	2.0	2.3	0.001263	9.6
DMA1	90	S4	1.10	2.75	2.76	2.73	1380	0.78	72.8	4.6	2.1	2.4	0.002761	12.5
DMA1	90	L4	1.50	3.72	3.78	3.93	1370	0.77	73.9	4.6	2.1	2.4	0.003283	15.0
DMA1	100	L4	2.20	5.13	5.12	4.80	1430	0.76	80.5	5.7	2.2	2.7	0.003119	19.2
DMA1	100	LX4	3.00	6.78	6.66	6.51	1400	0.82	79.5	5.2	2.0	2.6	0.004704	23.0
DMA1	112	M4	4.00	8.93	8.48	8.08	1430	0.82	83.2	5.8	2.1	2.6	0.006418	29.0
DMA1	132	S4	5.50	11.80	11.39	10.84	1435	0.85	82.3	6.5	2.0	2.5	0.013249	43.5
DMA1	132	M4	7.50	15.77	15.50	14.77	1435	0.82	84.8	6.5	2.2	2.5	0.016912	61.0
DM1	160	M4	11.00	22.1	21.2	21.3	1450	0.85	88.1	7.6	2.5	3.0	0.0724	113
DM1	160	L4	15.00	27.6	28.1	28.2	1460	0.86	89.5	7.9	2.7	3.1	0.0929	133
DM1	180	M4	18.50	35.3	33.4	33.4	1470	0.88	90.9	7.5	2.5	3.0	0.1350	167
DM1	180	L4	22.00	42.0	39.8	39.5	1465	0.88	90.9	7.5	2.2	3.1	0.1360	181
DM1	200	L4	30.00	55.6	53.3	52.0	1480	0.88	92.0	7.2	2.5	3.2	0.2450	232
DM1	225	S4	37.00	68.2	65.5	64.0	1485	0.88	92.3	7.3	2.0	2.8	0.3900	287
DM1	225	M4	45.00	81.3	79.1	76.0	1480	0.89	92.4	7.5	2.2	3.0	0.4500	322
DM1	250	M4	55.00	101	96.0	95.0	1480	0.89	93.0	7.0	2.3	3.1	0.6400	381
DM1	280	S4	75.00	137	131	126	1480	0.88	93.5	6.1	2.0	2.9	1.0450	510
DM1	280	M4	90.00	168	152	155	1485	0.88	94.2	7.8	2.7	3.3	1.3960	600

6POLE/1000 RPM

DMA1 = aluminium series 1 DM1 = cast iron series 1 IEC-DIN			Rated Output Power PN kW	Full Load Current			Full-Load Speed nN min-1	Full-Load Power Factor cos	Full-Load Efficiency %	Locked Rotor Current La/LN	Locked Rotor Torque Ma/MN	Breakdown Torque Mk/MN	Moment of Inertia J kgm2	Nett Weight IM B3 m kg
				380 V IU A	400 V IN A	420 V IO A								
DMA1	80	K6	0.37	1.19	1.26	1.26	915	0.67	63.0	3.5	2.0	2.4	0.001268	8.5
DMA1	80	G6	0.55	1.81	1.85	2.26	900	0.71	60.5	3.2	2.0	2.3	0.001392	9.2
DMA1	90	S6	0.75	2.35	2.31	2.30	910	0.71	65.6	3.5	2.0	2.3	0.00316	12.0
DMA1	90	L6	1.10	3.38	3.44	3.40	910	0.67	69.1	3.7	2.1	2.3	0.003794	14.0
DMA1	100	L6	1.50	3.92	3.88	3.87	935	0.76	73.3	4.1	1.9	2.2	0.004605	19.5
DMA1	112	M6	2.20	5.79	5.48	5.24	945	0.75	77.4	5.0	2.0	2.4	0.006949	28.0
DMA1	132	S6	3.00	7.39	7.07	6.97	960	0.78	78.3	5.4	1.8	2.2	0.012912	50.0
DMA1	132	M6	4.00	9.44	9.35	9.60	955	0.77	80.6	5.4	1.9	2.1	0.016082	58.0
DMA1	132	MX6	5.50	13.00	12.60	12.80	955	0.77	84.3	5.4	2.0	2.4	0.019174	65.0
DM1	160	M6	7.50	16.1	15.9	16.0	965	0.79	85.3	6.5	1.8	3.0	0.0800	108
DM1	160	L6	11.00	22.7	22.4	22.6	970	0.8	87.8	7.1	1.8	3.1	0.1080	131
DM1	180	L6	15.00	29.5	29.3	29.1	980	0.83	89.2	7.2	2.5	2.9	0.1670	171
DM1	200	L6	18.50	36.5	35.5	35.1	980	0.84	89.9	6.7	2.0	3.0	0.3020	216
DM1	200	LX6	22.00	42.3	40.6	39.8	975	0.87	89.8	6.7	2.0	2.8	0.3420	225
DM1	225	M6	30.00	57.6	55.4	54.2	985	0.85	91.7	6.2	2.3	2.8	0.5250	292
DM1	250	M6	37.00	69.5	67.3	65.7	985	0.87	91.5	6.8	2.1	3.1	0.8070	408
DM1	280	S6	45.00	79.1	80.2	77.3	985	0.88	92.4	6.5	2.0	2.9	1.3340	465
DM1	280	M6	55.00	97.6	99.0	95.4	985	0.87	92.7	6.7	2.1	3.0	1.5980	540

Electric Motor Dimensions

DM1 : 4 POLE/1500 RPM

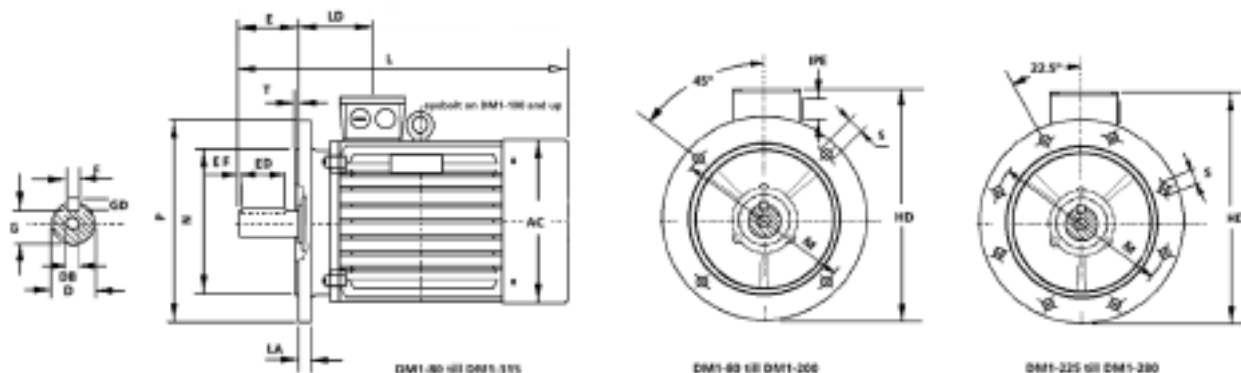

Type	Frame	Poles	AC	D	E	ED	EF	F	G	GD	HD	L	LA	LD
DMA1	80	4/6	146	19	40	25	7.5	6	15.5	6	224	268	12	83
DMA1	90S	4/6	158	24	50	32	7.5	8	20	7	230	312	12	88
DMA1	90L	4/6	158	24	50	32	7.5	8	20	7	230	332	12	88
DMA1	100	4/6	190	28	60	45	7.5	8	24	7	271	367	15	83
DMA1	112	4/6	216	28	60	45	7.5	8	24	7	290	384	15	100
DMA1	132S	4/6	246	38	80	56	7.5	10	33	8	330	445	15	105
DMA1	132M	4/6	246	38	80	56	7.5	10	33	8	330	483	15	105
DM1	160M/MX	4/6	311	42	110	100	5.0	12	37	8	505	615	14	150
DM1	160L	4/6	311	42	110	100	5.0	12	37	8	505	670	14	150
DM1	180M	4/6	352	48	110	100	5.0	14	42.5	9	530	700	16	160
DM1	180L	4/6	352	48	110	100	5.0	14	42.5	9	530	740	16	160
DM1	200L/LX	4/6	394	55	110	100	5.0	16	49	10	580	770	17	190
DM1	225S	4	442	60	140	125	7.5	18	53	11	640	815	20	190
DM1	225M	4/6	442	60	140	125	7.5	18	53	11	640	845	20	190
DM1	250M	4/6	481	65	140	125	7.5	18	58	11	695	910	20	203
DM1	280S	4/6	543	75	140	125	7.5	20	67.5	12	770	995	23	220
DM1	280M	4/6	543	75	140	125	7.5	20	67.5	12	770	1045	23	220

Type	Frame	Poles	M	N	P	S	T	Flange	IPE	X	Y
DMA1	80	4/6	165	130j6	200	4x12	3.5	FF165	2xPg16	80	65
DMA1	90S	4/6	165	130j6	200	4x12	3.5	FF165	2xPg16	80	65
DMA1	90L	4/6	165	130j6	200	4x12	3.5	FF165	2xPg16	80	65
DMA1	100	4/6	215	180j6	250	4x15	4	FF215	2xPg16	80	65
DMA1	112	4/6	215	180j6	250	4x15	4	FF215	2xPg21	100	100
DMA1	132S	4/6	265	230j6	300	4x15	4	FF265	2xPg21	100	100
DMA1	132M	4/6	265	230j6	300	4x15	4	FF265	2xPg21	100	100
DM1	160M/MX	4/6	300	250j6	350	4x19	5	FF300	2xPg29	150	160
DM1	160L	4/6	300	250j6	350	4x19	5	FF300	2xPg29	150	160
DM1	180M	4/6	300	250j6	350	4x19	5	FF300	2xPg29	150	160
DM1	180L	4/6	300	250j6	350	4x19	5	FF300	2xPg29	150	160
DM1	200L/LX	4/6	350	300h6	400	4x19	5	FF350	2xPg36	188	208
DM1	225S	4	400	350h6	450	8x19	5	FF400	2xPg36	188	208
DM1	225M	4/6	400	350h6	450	8x19	5	FF400	2xPg36	188	208
DM1	250M	4/6	500	450h6	550	8x19	5	FF500	2xPg42	216	246
DM1	280S	4/6	500	450h6	550	8x19	5	FF550	2xPg42	216	246
DM1	280M	4/6	500	450h6	550	8x19	5	FF500	2xPg42	216	246

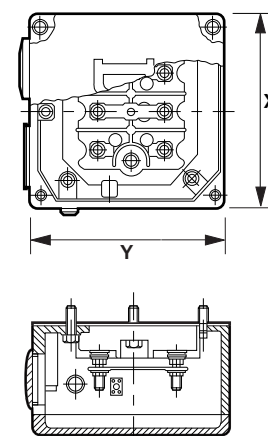

Electric Motor - Terminal Box Position

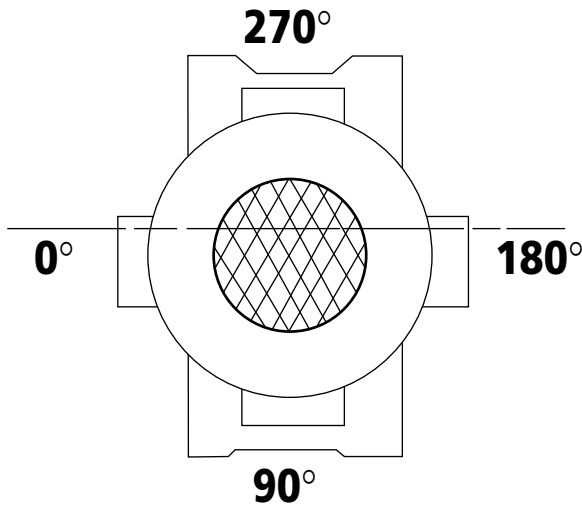

Terminal Box Position	
A	0°
B	90°
C	180°
D	270°

Unless otherwise specified-position 'A' will be issued.

Terminal Box

On motor sizes 71 to 225 the terminal box is an integral part of the frame.

Motor sizes 250 and above have a conventional terminal box that can rotate 180°. As standard in this range the terminal box entries are on the right side of the motor viewed from shaft end.

By rotating the terminal box, these entries can be transferred to the left side.

On the table below are the standard terminal arrangements and terminal box entries.

Motor Frame Size	Quantities and sizes		
	Terminals	Terminal box entries	
71	6 X M4	2 X Ø22,5	(1)
100	6 X M4	2 X Ø28,5	(1)
112	6 X M4	4 X Ø28,5	(2)
132	6 X M6	4 X Ø28,5	(2)
160	6 X M6	4 X Ø37	(2)
180	6 X M8	4 X Ø37	(2)
200 and 255	6 X M8	4 X Ø47	(2)
250 and 280	6 X M10	2 X Pg 42	(3)
315	6 X M10	2 X Pg 48	(3)
315 to 400	6 X M12	2 X Pg 48	(3)

- (1) One entry on each side
- (2) Two entries on each side
- (3) Two entries on the right side that can be transferred to the left side.

Alternative Types of TEFV Motors

Single phase	Capacitor start / induction run Permanent capacitor Capacitor start / capacitor run
Three phase	Squirrel cage standard motors Two speed Increased safety - Eex e Flameproof Exd. non sparking Exn. Brake motors Marine requirements Smoke extract duty High Efficiency motors Dust Ignition Proof - BS6467 Zone Z Force ventilation + Encoders + Tacho's Variable speed drives Motor-inverter combination Wash down Tropicalised DC Hydraulic Air

Ordering Procedure - Unit Designation Code

To ensure that the correct PM Series PH Type unit is supplied and that your order is processed without delay, please quote the full designation code as detailed below:

Motorised Unit

	PH4	SC	D4P	040	UA	M	A	TS	
Unit type and size	Special features
Ratio Code	Motor terminal box (see page 12)
D flange 4 pole motor	Metric 'M' or American 'A' shafts
4kW motor	Unit hand of assembly (see page 8-9)

Motorised Ready Unit - To suit free issue motor

	PH4	SC	D80RDY	UA	M	WP	
Unit type and size	Special features
Ratio Code	Metric 'M' or American 'A' shafts
D80 motor ready	Unit hand of assembly (see page 8-9)

Reduction Gear or Speed Reducer Unit

	PH6	Red XXX	SK	UA	M	SS	
Unit type and size	Special features
Reduction gear	Metric 'M' or American 'A' shafts
Ratio Code	Unit hand of assembly (see page 8-9)

Special Features include:-

- BM - Braked motor
- SS - Slow speed running
- WP - Weather proof
- TR - Torque restraint bracket
- SD - Shrink disc
- TA - Torque arm bracket

Ratio codes for gear units PH35 to PH50 only

RATIO	CODE	RATIO	CODE	RATIO	CODE	RATIO	CODE	RATIO	CODE
016	SA	032	SD	063	SG	125	SK	250	SN
020	SB	040	SE	080	SH	160	SL	320	SP
025	SC	050	SF	100	SJ	200	SM		

Ratio codes for gear units PH60 to PH80 only

RATIO	CODE	RATIO	CODE	RATIO	CODE	RATIO	CODE	RATIO	CODE
016	TA	032	TD	063	TG	125	TK	250	TN
020	TB	040	TE	080	TH	160	TL	320	TP
025	TC	050	TF	100	TJ				

RENOLD PM Series - PH Type Inertia Values WR^2 (kgm²)

Input Shaft - Reduction

Nominal Ratio	PH35	PH40	PH50	PH60	PH70	PH80
16	0.00098	0.00098	0.00098	0.00496	0.00496	0.00496
20	0.00079	0.00079	0.00079	0.00331	0.00331	0.00331
25	0.00063	0.00063	0.00063	0.00297	0.00297	0.00297
32	0.00058	0.00058	0.00058	0.00254	0.00254	0.00254
40	0.00056	0.00056	0.00056	0.00226	0.00226	0.00226
50	0.00054	0.00054	0.00054	0.00217	0.00217	0.00217
63	0.00054	0.00054	0.00054	0.00212	0.00212	0.00212
80	0.00053	0.00053	0.00053	0.00207	0.00207	0.00207
100	0.00053	0.00053	0.00053	0.00206	0.00206	0.00206
125	0.00053	0.00053	0.00053	0.00212	0.00212	0.00212
160	0.00053	0.00053	0.00053	0.00207	0.00207	0.00207
200	0.00053	0.00053	0.00053	0.00206	0.00837	0.00837
250	0.00053	0.00053	0.00053	0.00206	0.00206	0.00206
320	-	-	-	-	0.00206	0.00206

Input Shaft - Motorised

Nominal Ratio	PH35	PH40	PH50	PH60	PH70	PH80
16	0.00118	0.00118	0.00118	0.00611	0.00611	0.00611
20	0.00099	0.00099	0.00099	0.00446	0.00446	0.00446
25	0.00083	0.00083	0.00083	0.00412	0.00412	0.00412
32	0.00078	0.00078	0.00078	0.00369	0.00369	0.00369
40	0.00076	0.00076	0.00076	0.00341	0.00341	0.00341
50	0.00074	0.00074	0.00074	0.00332	0.00332	0.00332
63	0.00074	0.00074	0.00074	0.00327	0.00327	0.00327
80	0.00073	0.00073	0.00073	0.00322	0.00322	0.00322
100	0.00073	0.00073	0.00073	0.00321	0.00321	0.00321
125	0.00073	0.00073	0.00073	0.00327	0.00327	0.00327
160	0.00073	0.00073	0.00073	0.00322	0.00322	0.00322
200	0.00073	0.00073	0.00073	0.00321	0.00324	0.00321
250	0.00073	0.00073	0.00073	0.00321	0.00321	0.00321
320	-	-	-	-	0.00321	0.00321

Worm-line

Nominal Ratio	PH35	PH40	PH50	PH60	PH70	PH80
16	0.00070	0.00106	0.00204	0.00617	0.00763	0.01002
20	0.00088	0.00124	0.00222	0.00752	0.00898	0.01137
25	0.00109	0.00145	0.00243	0.00961	0.01107	0.01346
32	0.00137	0.00173	0.00271	0.01174	0.01320	0.01559
40	0.00154	0.00190	0.00288	0.01356	0.01502	0.01741
50	0.00187	0.00223	0.00321	0.01566	0.01712	0.01951
63	0.00219	0.00254	0.00353	0.01757	0.01903	0.02142
80	0.00256	0.00291	0.00390	0.02143	0.02289	0.02528
100	0.00287	0.00322	0.00421	0.02331	0.02477	0.02716
125	0.00310	0.00345	0.00444	0.01770	0.01903	0.02142
160	0.00256	0.00291	0.00390	0.02156	0.02289	0.02628
200	0.00287	0.00322	0.00421	0.02344	0.02115	0.02454
250	0.00310	0.00345	0.00444	0.02546	0.02477	0.02816
320	-	-	-	-	0.02679	0.03018

Wheel-line

Nominal Ratio	PH35	PH40	PH50	PH60	PH70	PH80
16	0.02000	0.05867	0.09605	0.21897	0.49541	0.70001
20	0.02000	0.05867	0.09605	0.21897	0.49541	0.70001
25	0.02000	0.05867	0.09605	0.21897	0.49541	0.70001
32	0.02000	0.05867	0.09605	0.21897	0.49541	0.70001
40	0.02000	0.05867	0.09562	0.21897	0.49541	0.70001
50	0.02000	0.05867	0.09562	0.21897	0.49541	0.70001
63	0.02000	0.05941	0.09562	0.21897	0.49541	0.70001
80	0.02000	0.05941	0.09562	0.21897	0.49541	0.70001
100	0.02000	0.05941	0.09562	0.21897	0.49541	0.70001
125	0.02000	0.05941	0.09562	0.20231	0.49541	0.70001
160	0.02000	0.05941	0.09562	0.20231	0.48478	0.75270
200	0.02000	0.05941	0.09562	0.20231	0.48478	0.75270
250	0.02000	0.05941	0.09562	0.20231	0.48478	0.75270
320	-	-	-	-	0.48478	0.75270

Wheel-line

Type	PH35	PH40	PH50	PH60	PH70	PH80
Single Ext	0.00135	0.00305	0.00689	0.01972	0.03465	0.03846
Single Ext - Flanged	0.00178	0.00421	0.00868	0.02438	0.04309	0.04619
Double Ext	0.00169	0.00385	0.00884	0.02315	0.04157	0.04918
Double Ext - Flanged	0.00213	0.00500	0.01062	0.00278	0.05000	0.05763

RENOLD PM Series -Selection Information

To select a motorised or non-motorised gear unit for an application, the following information must be available.

Power/Torque

- a) Input or output (kW) or torque (Nm).
- b) Type and power output of prime mover (kW). Required mounting position.
- c) For input speeds below 250 rev/min consult our Technical Sales Department giving details of required output torque (Nm) and diameter of driven shaft (mm).

Speed

Gear unit input and output rev/min.

Duty

- a) The characteristics of the drive eg. degree of impulsiveness of the driven load.
- b) Duration of service in hours/day.
- c) Starting load (kW) and number of starts per day.
- d) For intermittent duty, reversing or shock loading, state normal power (kW) and frequency.
- e) Disposition and details of external loads imposed on input/output shafts.
Diameter of driven shaft in the case shaft mounting arrangement.
- f) Working conditions, i.e. clean, dusty, moist, abnormal temperatures etc.

If the operating conditions are in any way unusual it is advisable to consult our Technical Sales Department.

Enquiry/Ordering Procedure

At the order or enquiry stage, please quote the catalogue reference, shaft assembly number and nominal ratio or exact ratio if this important (see tables). Non standard mounting positions should be indicated with a sketch. Where a double extension wormwheel shaft is required, please state any special requirements regarding alignment of keyways.

Mechanical Rating

The mechanical powers listed are those which the PM Series units will transmit for 10 hours each day and correspond to a service factor of 1,0. Where non-uniform loading or a working day other than 10 hours is involved, a service factor f_D should be applied to the selection power or torque which is taken from table 2. High numbers of

starts per hour also influence the mechanical selection. Table 3 shows the starts factor f_S which should also be applied to the selection power or torque.

For guidance a comprehensive list of the various load conditions for a number of applications is given in Table 1. When confirming the mechanical selection powers therefore, the rating must be equal to or greater than calculated power or torque demand x application service factor f_D (table 1 and table 2) x starts factor f_S (table 3)

Efficiencies

The efficiency figures are approximate only and are those that could be expected from a gearbox which is fully run-in and operating under full load with the lubricant at its full working temperature.

For intermittent rating where the lubricant may remain comparatively cool, the efficiency may be somewhat lower due to the increased oil churning losses associated with the higher viscosity of the cool oil. We shall be pleased to advise on any particular application.

Thermal Rating

The thermal ratings given are those which the gear units will transmit at an ambient temperature of 20°C, when the heat generated within the gearbox is being dissipated at the same rate. Whilst these ratings can be exceeded under start up conditions, this situation could lead to overheating and subsequent damage if continuously applied. Thermal torque ratings do not relate to mechanical gear life and are not affected by running time or momentary shock loads. If the ambient temperature is likely to exceed 20°C, this situation will have to be taken into account in the selection procedure. This is done by applying the thermal service factor given in table 4 when calculating the selection output torque.

E.g. Thermal selection torque = continuous torque requirement X thermal service factor f_T . Where intermittent running is involved it is possible the thermal limitation can be ignored, such as on a crane or winch application, and when this type of operation is being considered full applicational details should be given to Renold for assessment.

Selection Procedure**MOTORISED UNIT SELECTION PROCEDURE
PM SERIES MOTORISED**

To select a PM series motorised unit, the following procedure should be followed.

- a) Determine required output speed.
- b) Select the total Mechanical Service Factor f_D (table 2) and Starts Factor f_S (table 3)
Total Mechanical Service Factor = $f_D \times f_S$
- c) Determine the power absorbed by the machine.
Absorbed Power (kW) = $\frac{\text{Absorbed torque (Nm)} \times \text{Speed (RPM)}}{9550}$
- d) Select an electric motor that will give an output power greater than that of the absorbed power above.
- e) Select a gear unit from the tables on pages 19 to 31 using the motor power and the output speed as the basis. Ensure that the Mechanical service factor S_F of the unit selected exceeds the selection factor from b) above.

**NON-MOTORISED UNIT
SELECTION PROCEDURE**

When a non-motorised gear unit is under consideration proceed as follows:-

- a) Establish the ratio, input speed and input power or output torque required.
- b) Determine the Load Classification for the appropriate application from table 1 and the corresponding Service Factor from table 2. Multiply this by the factor for starts per hour in table 3. The input power or output torque in 1 must now be multiplied by this factor in order to establish the required mechanical rating. This value must be equal to or less than the Mechanical Rating listed against the appropriate rating and input speed shown on pages 38 to 51.
- c) Determine the Thermal Service factor from table 4 and multiply the input power or output torque in 1 by this figure. The Thermal Rating appropriate to the unit tentatively selected in 2 must be equal to or greater than this value.
- d) Where an output shaft is fitted, check that any Overhung and/or Axial loads applied are within the capabilities of the unit - see page 36.

RENOLD PM Series - Selection Examples

Mechanical Selection Torque	Nm =	Actual Torque (Nm) Requirement	X	Mechanical Service (fd) Factor	X	Starts (fs) Factors
Thermal Selection Torque	Nm =	Actual Torque (Nm) Requirement	X	Thermal Service (fr) Factor		
Mechanical Selection Power	(kW) =	Actual Power (kW) Requirement	X	Mechanical Service (fd) Factor	X	Starts (fs) Factor
Thermal Selection Power	(kW) =	Actual Power (kW) Requirement	X	Thermal Service (fr) Factor		

Example 1 [Motorised Unit]

A motorised gear unit is required to drive an inclined chain conveyor having a headshaft torque of 4200Nm, operating for 24 hours per day continuously at 45 RPM. The duty is is considered a steady load.

$$a) \text{ Approximate motor power (kW)} = \frac{4200 \times 45}{9550} = 19.8 \text{ kW}$$

Nearest motor power is 22 kW.

b) From the Load Classification and Service Factor tables 1 and 2, a steady load operating 24 hours/day the duty factor $f_D = 1.25$.

c) The starts factor from table 3 for continuous running is $f_S = 1$.

$$d) \text{ Total selection factor } S = f_D \times f_S = 1.25 \times 1 = 1.25$$

e) From the selection tables on pages 19 to 31 a 22kW drive can be found on page 31. 43 RPM is the closest speed to the one required offering a mechanical service factor SF of 1.26 which satisfies the selection factor in d) above.

The selected unit is a **PH8SDD4P220*****

MOTORISED UNIT INERTIA

$$\text{Total Input Shaft inertia} = \text{motor inertia [page 10]} + \text{motorised input shaft inertia [page 14]}$$

$$\text{Wormline inertia} = \text{Wormline inertia [page 14]}$$

$$\text{Hollow output Shaft inertia} = \text{Hollow output shaft inertia [page 14]}$$

$$\text{Total plug-in Output shaft Inertia} = \text{Hollow output shaft inertia [page 14]} + \text{plug-in shaft inertia [page 14]}$$

$$\text{TOTAL INERTIA VALUES With respect to INPUT} = \text{input shaft values} + \frac{\text{wormline values}}{\text{helical ratio}^2} + \frac{\text{output values}}{\text{overall actual ratio}^2}$$

$$\text{TOTAL INERTIA VALUES With respect to OUTPUT} = \text{output values} + \text{wormline x worm ratio}^2 + \text{input shaft X overall actual ratio values}$$

Example 2 Non-Motorised Unit [Speed Reducer]

A right angle gear unit is required to drive a machine using an electric motor as the prime mover @ 1500 RPM. The output torque required is 2100Nm with a gear ratio of 100:1. The duty cycle is heavy shock load, 10 hours/day running with 7 stops/starts per hour. Maximum ambient temperature is 32 degrees C.

$$a) \text{ mechanical selection torque} = \text{Actual torque} \times \text{mechanical service factor } f_D \times \text{starts factor } f_S$$

= 2100 X 1.75 X 1.2 = 4410 Nm

$$b) \text{ Thermal Selection Torque} = \text{Actual torque} \times \text{Thermal service factor } f_T$$

= 2100 X 1.16 = 2436 Nm

The selection tables on page 38 to 51 show that for a gear ratio of 100:1 page 46 @ 1500 RPM the PH 6 unit is the size that fulfills both the selection criteria in a) and b)

The unit selection is **PH6REDXXSJ*****

NON MOTORISED INERTIA [SPEED REDUCER]

$$\text{Total Input Shaft inertia} = \text{Input shaft speed reducer [page 14]}$$

$$\text{Wormline inertia} = \text{Wormline inertia [page 14]}$$

$$\text{Hollow output Shaft inertia} = \text{Hollow output shaft inertia [page 14]}$$

$$\text{Total plug-in Output shaft Inertia} = \text{Hollow output shaft inertia [page 14]} + \text{plug-in shaft inertia [page 14]}$$

RENOLD PM Series - Load Classification by Application

Table 1

Agitators		Sugar (1)	M	Medium duty	M	Individual drives	H	single acting: 1 or 2 cylinders	*
Pure liquids	S	Dredges	M	Skip hoist	M	Reversing	*	double acting: single cylinder	*
Liquids and solids	M	Cable reels	M	Laundry	M	Wire drawing and flattening machine	M	Rotary - gear type	S
Liquids-variable density	M	Conveyors	M	Washers - reversing	M	Wire winding machine	M	Rotary - lobe, vane	S
Blowers		Cutter head drives	H	Tumblers	M	Mills, rotary type		Rubber and plastics industries	
Centrifugal	M	Jig drives	H	Line shafts		Ball (1)	M	Crackers (1)	H
Lobe	S	Manoeuvring winches	M	Driving processing equipment	M	Cement kilns (1)	M	Laboratory equipment	M
Vane	S	Pumps	M	Light	S	Dryers and coolers (1)	M	Mixed mills (1)	H
Brewing and Distilling	S	Screen drive	H	Other line shafts	S	Kilns other than cement	M	Refiners (1)	M
Bottling machinery	S	Stackers	M	Lumber industry		Pebble (1)	M	Rubber calenders (1)	M
Brew kettles-continuous duty	S	Utility winches	M	Barkers, hydraulic, mechanical	M	Rod, plain & wedge bar (1)	M	Rubber mill, 2 on line (1)	M
Cookers-continuous duty	S	Dry dock cranes		Burner conveyor	M	Tumbling barrels	H	Rubber mill, 3 on line (1)	S
Mash tubs-continuous duty	S	Main hoist	(2)	Chain saw and drag saw	H	Mixers		Sheeter (1)	M
Scale hopper-frequent starts	M	Auxiliary hoist	(2)	Chain transfer	H	Concrete mixers continuous	M	Tyre building machines	*
Can filling machines		Boom, luffing	(2)	Crane/way transfer	H	Concrete mixers intermittent	M	Tyre and tube press openers	*
Cane knives (1)	M	Rotating, swing or slew	(3)	De-barking drum	H	Constant density	S	Tubers and strainers (1)	M
Car dumpers	H	Tracking, drive wheels	(4)	Edger feed	M	Variable density	M	Warming mills (1)	M
Car pullers	H	Elevators	(4)	Gang feed	M	Oil industry		Sand muller	M
Clarifiers	S	Bucket - uniform load	S	Green chain	S	Chillers	M	Screens	
Classifiers	M	Bucket - heavy load	M	Live rolls	H	Oil well pumping	*	Air washing	S
Clay working machinery		Bucket - continuous	M	Log deck	H	Paraffin filter press	M	Rotary, stone or gravel	M
Brick press	H	Centrifugal discharge	S	Log haul-incline	H	Rotary kilns	M	Travelling water intake	S
Briquette machine	H	Escalators	S	Log haul-well type	H	Paper mills		Sewage disposal equipment	
Clay working machinery	M	Freight	M	Log turning device	H	Agitators (mixers)	M	Bar screens	S
Pug mill	M	Gravity discharge	S	Main log conveyor	S	Barker-auxillaries hydraulic	M	Chemical feeders	S
Compressors	S	Man lifts	*	Off bearing rolls	M	Barker-mechanical	H	Collectors	S
Centrifugal	S	Passenger	*	Planer feed chains	M	Barking drum	H	Dewatering screws	M
Lobe	M	Extruders (plastic)		Planer floor chains	M	Beater and pulper	M	Scum breakers	M
Reciprocating - multi-cylinder	M	Film	S	Planer tilting hoist	M	Bleacher	S	Slow or rapid mixers	M
Reciprocating - single cylinder	H	Sheet	S	Re-saw merry-go-round conveyor	M	Calenders	M	Thickeners	M
Conveyors - uniformly loaded or fed		Coating	S	Roll cases	H	Calenders-super	H	Vacuum filters	M
Apron	S	Rods	S	Slab conveyor	H	Converting machine except	M	Slab pushers	M
Assembly	S	Tubing	S	Small waste conveyor-belt	S	cutters, platers	M	Steering gear	M
Belt	S	Blow moulders	M	Small waste conveyor-chain	M	Conveyors	S	Stokers	S
Bucket	S	Pre-plasticiers	M	Sorting table	M	Couch	M	Sugar industry	
Chain	S	Fans	S	Tipple hoist conveyor	M	Cutters, platers	H	Cane knives (1)	M
Flight	S	Centrifugal	S	Tipple hoist drive	M	Cylinders	M	Crushers (1)	M
Oven	S	Cooling towers	S	Transfer conveyors	M	Dryers	M	Mills (1)	M
Screw	S	Induced draft	*	Transfer rolls	M	Fell stretcher	M	Textile industry	
Conveyors - heavy duty		Forced draft	*	Tray drive	M	Fell whipper	H	Batchers	M
not uniformly fed		Induced draft	M	Trimmer feed	M	Jordans	M	Calenders	M
Apron	M	Large, mine etc.	M	Waste conveyor	M	Log haul	H	Cards	M
Assembly	M	Large, industrial	M	Machine tools		Presses	M	Dry cans	M
Belt	M	Light, small diameter	S	Bending roll	S	Pulp machine reel	M	Dryers	M
Bucket	M	Feeders	S	Punch press-gear driven	H	Stock chest	M	Dyeing machinery	M
Chain	M	Apron	M	Nothing press-belt drive	*	* Suction roll	M	Looms	M
Flight	M	Belt	M	Plate planners	H	Washers and thickeners	M	Mangles	M
Live roll	*	Disc	S	Tapping machine	H	Winders	M	Nappers	M
Oven	M	Reciprocating	H	Other machine tools		Printing presses	*	Pads	M
Reciprocating	H	Screw	M	Main drives	M	Pullers		Range drives	M
Screw	H	Food industry		Auxiliary drives	S	Barge haul	H	Slashers	M
Shaker	M	Beef slicer	M	Metal mills		Pumps		Soapers	M
Crane Drives - not dry dock	H	Cereal cooker	S	Drawn bench carriage and main drive	S	Centrifugal	S	Spinners	M
Main hoists	S	Dough mixer	M	Pinch, dryer and scrubber rolls, reversing	M	Proportioning	M	Tenter frames	M
Bridge travel	*	Meat grinder	M	Slitters	H	Reciprocating	M	Washers	M
Trolley travel	*	Generators - not welding		Table conveyors non-reversing gear drives	H	single acting:	*	Winders	M
Crushers		Hammer mills				3 or more cylinders	M	Windlass	*
Ore	H	Hoists				double acting:			
Stone	H	Heavy duty	H			2 or more cylinders	M		

Service Factors

Table 2 (Service Factor f_D)

Prime mover (Drive input)	Driven machinery characteristics			
	Duration Service hours/day	Steady load	Medium impulsive	Highly impulsive
Electric, Air & Hydraulic Motors or Steam Turbine (Steady input)	Intermittent - 3hrs/day max	0.90	1.00	1.50
	3 - 10	1.00	1.25	1.75
	over 10	1.25	1.50	2.00
Multi-cylinder I.C. engine (Medium impulsive input)	Intermittent - 3hrs/day max	1.00	1.25	1.75
	3 - 10	1.25	1.50	2.00
	over 10	1.50	1.75	2.25
Single-cylinder I.C. engine (Highly impulsive input)	Intermittent - 3hrs/day max	1.25	1.50	2.00
	3 - 10	1.50	1.75	2.25
	over 10	1.75	2.00	2.50

Table 3 Factor for Starts/Hours (f_S)

Maximum number of starts per hour	0 - 1	1 - 30	30 - 60	60
Starts Factor f_S	1.0	1.2	1.3	1.5

S = Steady

M = Medium Impulsive

H = Highly Impulsive

* = Refer to Renold

(1) = Select on 24 hours per day service factor only.

(2) = Use service factor of 1.00 for any duration of service.

(3) = Use service factor of 1.25 for any duration of service.

(4) = Use service factor of 1.50 for any duration of service.

Note

Machinery characteristics and service factors listed in this catalogue are a guide only. Some applications (e.g. constant power) may require special considerations. Consult Renold Gears.



IMPORTANT

Units to ATEX approval must be selected with a minimum service factor of 1.25.

Table 4 Thermal Service Factor f_T

Ambient °C	10	20	30	40	50	60
	Temp °F	50	68	86	105	122
Factor f_T	0.87	1.0	1.16	1.35	1.62	1.97

RENOLD PM Series - Overhung and Thrust Loads

Output shafts of worm gear units are frequently fitted with a spur pinion, chain pinion or belt pulley causing an overhung load to be imposed on the output shaft and bearings. These loads can generally be sustained by the gear unit; however, if the load is greater than the maximum allowable load for the unit, it may be necessary to either select a larger unit or to lessen the effect of the load on the shaft bearings. This can be done in two ways. The pinion can be mounted on a shaft in its own bearings and the shaft coupled to the gear unit; or the wheel shaft may be extended beyond the overhung load and fitted with an outboard bearing. In order to obtain the best possible arrangement for a particular application (where large over hung loads are anticipated) customers are advised to submit details of the load to our Sales Technical Staff for their consideration.

In the interests of good design, the overhung member should be fitted as close as possible to the gear case in order to minimise the stresses and reduce the deflecting moment on the unit.

The maximum imposed axial thrust and overhung loads to which the units can be subjected are given in tables 5 and 6.

Imposed axial thrust loads can also be minimised by the use of flexible couplings on the input and output shafts.

For drives where both imposed thrust and overhung loads are encountered, it is advisable to consult our Technical Sales Staff.

Where a double extension shaft is fitted, the maximum overhung loads listed apply in full to each shaft extension.

Unit Size	X
PH35	165
PH40	175
PH50	210
PH60	235
PH70	270
PH80	270

- based on Single Extension Plug-in Shaft

The overhung load may be calculated by the following formula:

$$\frac{9.55P \times 10^6 \times F \text{ (Newtons)}}{R \times S}$$

Where P = Power absorbed at output shaft (kW)

S = Speed of output shaft in rev/min

R = Pitch circle radius of chain pinion, spur or helical gear, or belt pulley in mm.

F = Overhung drive application factor as follows:

Chain pinion 1.00

Spur or helical gear 1.25

Vee pulley 1.50

Flat belt pulley 2.00

The overhung load capacities listed in table 5 assume the load is applied mid-way along the output shaft extension, the relevant dimension from the centre line of the unit being as given below.

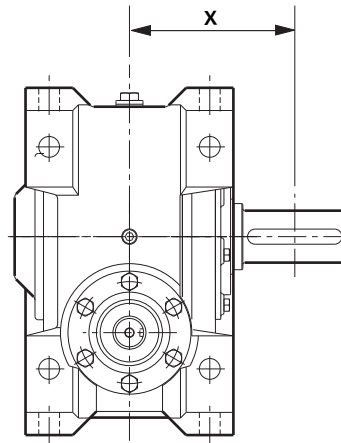

RENOLD PM Series - PH Type - Motorised - Selection Data

P1 0.55 kW		4P - D80KD 1365 RPM				
		6P - D80GD 900 RPM				
n_2	Actual Ratio	M_2	S_F	Overhung Load	Axial Load	Product Code
rpm	i	Nm		(max.) N	(max.) N	
88	15.50	51	10.61	9000	16000	PH3SAD4P005***
67	20.43	67	8.77	9000	16000	PH3SBD4P005***
52	26.11	85	7.61	9000	16000	PH3SCD4P005***
40	33.91	109	6.43	9000	16000	PH3SDD4P005***
35	39.02	125	5.85	9000	16000	PH3SED4P005***
27	50.38	160	4.95	9000	16000	PH3SFD4P005***
21	63.55	201	4.21	9000	16000	PH3SGD4P005***
16	83.31	261	3.45	9000	16000	PH3SHD4P005***
13	106.12	329	2.93	9000	16000	PH3SJD4P005***
11	128.23	394	2.56	9000	16000	PH3SKD4P005***
8.5	161.25	464	3.03	18000	20000	PH4SLD4P005***
8.5	161.25	436	2.13	9000	16000	PH3SLD4P005***
6.6	205.38	588	4.84	25000	35000	PH5SMD4P005***
6.6	205.38	584	2.41	18000	20000	PH4SMD4P005***
6.6	205.38	546	1.81	9000	16000	PH3SMD4P005***
5.5	248.18	704	4.21	25000	35000	PH5SND4P005***
5.5	248.18	699	2.01	18000	20000	PH4SND4P005***
5.5	248.18	651	1.58	9000	16000	PH3SND4P005***
4.4	205.38	873	3.39	25000	35000	PH5SMD6P005***
4.4	205.38	875	1.60	18000	20000	PH4SMD6P005***
4.4	205.38	804	1.33	8350	16000	PH3SMD6P005***
3.6	248.18	1047	2.82	25000	35000	PH5SND6P005***
3.6	248.18	1047	1.33	18000	20000	PH4SND6P005***
3.6	248.18	961	1.15	5450	16000	PH3SND6P005***

The overhung load shown above is based on the maximum motor Power being transmitted. For higher overhung loads consult Renold.

Key

n_2 Output Speed, rpm
 i Overall Ratio
 M_2 Output Torque Nm, Mechanical
 S_F Service Factor, Mechanical

For details of unit designation code see page 13.

* Max. Standard Plug-in Shaft Torque Nm

PH35	PH40	PH50	PH60	PH70	PH80
1045	1705	3040	4300	6090	8025

Overhung Load Capacity is that what can be applied along with the lower of either M_2 or the value stated in the table above.



Units to ATEX approval must be selected with a minimum service factor of 1.25.

RENOLD PM Series - PH Type - Motorised - Selection Data

P1		0.75 kW			4P - D80GD 1345 RPM		6P - D90SD 910 RPM	
n ₂	Actual Ratio	M ₂	S _F	Overhung Load	Axial Load	Product Code		
rpm	i	Nm		(max.) N	(max.) N			
87	15.50	71	7.61	9000	16000	PH3SAD4P007***		
66	20.43	93	6.31	9000	16000	PH3SBD4P007***		
52	26.11	118	5.48	9000	16000	PH3SCD4P007***		
40	33.91	152	4.64	9000	16000	PH3SDD4P007***		
34	39.02	174	4.23	9000	16000	PH3SED4P007***		
27	50.38	223	3.58	9000	16000	PH3SFD4P007***		
21	63.55	279	3.04	9000	16000	PH3SGD4P007***		
16	83.31	361	2.50	9000	16000	PH3SHD4P007***		
14	97.50	400	3.46	18000	20000	PH4SJD4P007***		
13	106.12	455	2.12	9000	16000	PH3SJD4P007***		
11	123.00	499	2.83	18000	20000	PH4SKD4P007***		
10	128.23	546	1.85	9000	16000	PH3SKD4P007***		
8.3	161.25	649	4.13	25000	35000	PH5SLD4P007***		
8.3	161.25	644	2.18	18000	20000	PH4SLD4P007***		
8.3	161.25	604	1.54	9000	16000	PH3SLD4P007***		
6.5	205.38	816	3.50	25000	35000	PH5SMD4P007***		
6.5	205.38	810	1.73	18000	20000	PH4SMD4P007***		
6.5	205.38	756	1.31	9000	16000	PH3SMD4P007***		
5.4	248.18	977	3.03	25000	35000	PH5SND4P007***		
5.4	248.18	968	1.45	18000	20000	PH4SND4P007***		
5.4	248.18	901	1.14	6700	16000	PH3SND4P007***		
4.4	205.38	1183	2.50	25000	35000	PH5SMD6P007***		
4.4	205.38	1183	1.18	18000	20000	PH4SMD6P007***		
4.4	205.38	1088	*0.99	3200	16000	PH3SMD6P007***		
3.7	248.18	1415	2.09	25000	35000	PH5SND6P007***		
3.7	248.18	1416	0.99	15900	20000	PH4SND6P007***		
3.7	248.18	1298	*0.85	3200	16000	PH3SND6P007***		

Key

- n₂ Output Speed, rpm
- i Overall Ratio
- M₂ Output Torque Nm, Mechanical
- S_F Service Factor, Mechanical

For details of unit designation code see page 13.

The overhung load shown above is based on the maximum motor Power being transmitted. For higher overhung loads consult Renold.

* Max. Standard Plug-in Shaft Torque Nm

PH35	PH40	PH50	PH60	PH70	PH80
1045	1705	3040	4300	6090	8025

Overhung Load Capacity is that what can be applied along with the lower of either M₂ or the value stated in the table above.



Units to ATEX approval must be selected with a minimum service factor of 1.25.

RENOLD PM Series - PH Type - Motorised - Selection Data

P1		1.1 kW		4P - D90SD 1380 RPM		
				6P - D90LD 910 RPM		
n ₂ rpm	Actual Ratio i	M ₂ Nm	S _F	Overhung Load (max.) N	Axial Load (max.) N	Product Code
89	15.50	102	5.21	9000	16000	PH3SAD4P011***
68	20.43	134	4.35	9000	16000	PH3SBD4P011***
53	26.11	170	3.78	9000	16000	PH3SCD4P011***
41	33.91	219	3.21	9000	16000	PH3SDD4P011***
35	39.02	251	2.92	9000	16000	PH3SED4P011***
27	50.38	327	3.34	18000	20000	PH4SFD4P011***
27	50.38	320	2.47	9000	16000	PH3SFD4P011***
22	63.55	400	2.10	9000	16000	PH3SGD4P011***
21	65.63	396	3.10	18000	20000	PH4SGD4P011***
18	75.52	452	2.83	18000	20000	PH4SHD4P011***
17	83.31	518	1.73	9000	16000	PH3SHD4P011***
14	97.50	580	4.09	25000	35000	PH5SJD4P011***
14	97.50	575	2.39	18000	20000	PH4SJD4P011***
13	106.12	653	1.47	9000	16000	PH3SJD4P011***
11	123.00	723	3.48	25000	35000	PH5SJD4P011***
11	123.00	716	1.97	18000	20000	PH4SJD4P011***
11	128.23	783	1.29	8650	16000	PH3SJD4P011***
8.6	161.25	933	2.86	25000	35000	PH5SJD4P011***
8.6	161.25	925	1.52	18000	20000	PH4SJD4P011***
8.6	161.25	866	1.07	7350	16000	PH3SJD4P011***
6.7	205.38	1173	2.42	25000	35000	PH5SJD4P011***
6.7	205.38	1161	1.21	18000	20000	PH4SJD4P011***
6.7	205.38	1085	*0.91	3200	16000	PH3SJD4P011***
5.6	248.18	1403	2.11	25000	35000	PH5SJD4P011***
5.6	248.18	1388	1.01	16200	20000	PH4SJD4P011***
5.6	248.18	1294	*0.79	3200	16000	PH3SJD4P011***
4.4	205.38	1739	1.70	25000	35000	PH5SJD6P011***
4.4	205.38	1738	*0.81	11100	20000	PH4SJD6P011***
3.7	248.18	2082	1.42	21800	35000	PH5SJD6P011***

The overhung load shown above is based on the maximum motor Power being transmitted. For higher overhung loads consult Renold.

* Max. Standard Plug-in Shaft Torque Nm

PH35	PH40	PH50	PH60	PH70	PH80
1045	1705	3040	4300	6090	8025

Overhung Load Capacity is that what can be applied along with the lower of either M₂ or the value stated in the table above.

Key

- n₂ Output Speed, rpm
- i Overall Ratio
- M₂ Output Torque Nm, Mechanical
- S_F Service Factor, Mechanical

For details of unit designation code see page 13.



IMPORTANT

Units to ATEX approval must be selected with a minimum service factor of 1.25.

RENOLD PM Series - PH Type - Motorised - Selection Data

P1		1.5 kW		4P - D90LD 1370 RPM		6P - D100LD 935 RPM	
n ₂	Actual Ratio	M ₂	S _F	Overhung Load	Axial Load	Product Code	
rpm	i	Nm		(max.) N	(max.) N		
88	15.50	142	3.79	9000	16000	PH3SAD4P015***	
67	20.43	185	3.16	9000	16000	PH3SBD4P015***	
52	26.11	234	2.75	9000	16000	PH3SCD4P015***	
40	33.91	307	3.34	18000	20000	PH4SDD4P015***	
40	33.91	301	2.33	9000	16000	PH3SDD4P015***	
35	39.02	351	3.04	18000	20000	PH4SED4P015***	
35	39.02	345	2.13	9000	16000	PH3SED4P015***	
35	39.55	338	5.37	25000	35000	PH5SED4P015***	
27	50.38	450	2.42	18000	20000	PH4SFD4P015***	
27	50.38	440	1.80	9000	16000	PH3SFD4P015***	
27	50.53	428	4.56	25000	35000	PH5SFD4P015***	
22	63.55	550	1.53	9000	16000	PH3SGD4P015***	
21	65.63	550	3.88	25000	35000	PH5SGD4P015***	
21	65.63	545	2.26	18000	20000	PH4SGD4P015***	
18	75.52	628	3.54	25000	35000	PH5SHD4P015***	
18	75.52	622	2.06	18000	20000	PH4SHD4P015***	
16	83.31	712	1.26	9000	16000	PH3SHD4P015***	
14	97.50	799	2.97	25000	35000	PH5SJD4P015***	
14	97.50	792	1.74	18000	20000	PH4SJD4P015***	
13	106.12	897	1.07	6750	16000	PH3SJD4P015***	
11	123.00	996	2.53	25000	35000	PH5SKD4P015***	
11	123.00	985	1.43	18000	20000	PH4SKD4P015***	
11	128.23	1075	0.94	2150	16000	PH3SKD4P015***	
9	101.54	1338	2.65	34000	50000	PH6SJD6P015***	
8	161.25	1285	2.08	25000	35000	PH5SLD4P015***	
8	161.25	1272	1.11	17800	20000	PH4SLD4P015***	
8	161.25	1192	0.78	#	16000	PH3SLD4P015***	
8	117.14	1378	2.84	34000	50000	PH6SKD6P015***	
8	123.46	1605	4.15	42000	55000	PH7SJD6P015***	
7	205.38	1616	1.76	25000	35000	PH5SMD4P015***	
7	205.38	1597	0.88	13100	20000	PH4SMD4P015***	
6	156.19	1771	3.23	42000	55000	PH7SKD6P015***	
6	248.18	1932	1.53	23200	35000	PH5SND4P015***	
5	176.00	2018	2.14	34000	50000	PH6SLD6P015***	
5	202.35	2250	2.71	42000	55000	PH7SLD6P015***	
5	207.69	2358	1.89	32500	50000	PH6SMD6P015***	
5	205.38	2314	1.28	19300	35000	PH5SMD6P015***	
4	248.18	2770	1.07	13100	35000	PH5SND6P015***	
4	246.92	2694	1.66	27600	50000	PH6SND6P015***	

P1		1.5 kW (cont)		4P - D90LD 1370 RPM		6P - D100LD 935 RPM	
n ₂	Actual Ratio	M ₂	S _F	Overhung Load	Axial Load	Product Code	
rpm	i	Nm		(max.) N	(max.) N		
3	276.92	3050	2.75	55000	55000	PH8SND6P015***	
3	276.92	3012	2.17	40400	55000	PH7SND6P015***	
3	329.23	3581	2.43	55000	55000	PH8SPD6P015***	
3	329.23	3538	1.90	35900	55000	PH7SPD6P015***	

Key

- n₂ Output Speed, rpm
- i Overall Ratio
- M₂ Output Torque Nm, Mechanical
- S_F Service Factor, Mechanical

For details of unit designation code see page 13.

The overhung load shown above is based on the maximum motor Power being transmitted. For higher overhung loads consult Renold.

* Max. Standard Plug-in Shaft Torque Nm

PH35	PH40	PH50	PH60	PH70	PH80
1045	1705	3040	4300	6090	8025

Overhung Load Capacity is that what can be applied along with the lower of either M₂ or the value stated in the table above.



Units to ATEX approval must be selected with a minimum service factor of 1.25.

RENOLD PM Series - PH Type - Motorised - Selection Data

P1 2.2 kW		4P - D100LD 1430 RPM					6P - D112MD 945 RPM						
n ₂	Actual Ratio	M ₂	S _F	Overhung Load	Axial Load	Product Code	n ₂	Actual Ratio	M ₂	S _F	Overhung Load	Axial Load	Product Code
rpm	i	Nm		(max.) N	(max.) N		rpm	i	Nm		(max.) N	(max.) N	
92.3	15.50	200	2.63	9000	16000	PH3SAD4P022***							
70.0	20.43	265	3.18	18000	20000	PH4SBD4P022***							
70.0	20.43	262	2.21	9000	16000	PH3SBD4P022***							
54.8	26.11	336	2.75	18000	20000	PH4SCD4P022***							
54.8	26.11	331	1.92	9000	16000	PH3SCD4P022***							
42.2	33.91	437	4.16	25000	35000	PH5SDD4P022***							
42.2	33.91	433	2.33	18000	20000	PH4SDD4P022***							
42.2	33.91	425	1.63	9000	16000	PH3SDD4P022***							
36.7	39.02	496	2.13	18000	20000	PH4SED4P022***							
36.7	39.02	486	1.49	9000	16000	PH3SED4P022***							
36.2	39.55	480	3.73	25000	35000	PH5SED4P022***							
28.4	50.38	634	1.72	18000	20000	PH4SFD4P022***							
28.4	50.38	621	1.26	9000	16000	PH3SFD4P022***							
28.3	50.53	607	3.16	25000	35000	PH5SFD4P022***							
22.5	63.55	775	1.08	8750	16000	PH3SGD4P022***							
21.8	65.63	778	2.70	25000	35000	PH5SGD4P022***							
21.8	65.63	770	1.58	18000	20000	PH4SGD4P022***							
18.9	75.52	889	2.47	25000	35000	PH5SHD4P022***							
18.9	75.52	880	1.44	18000	20000	PH4SHD4P022***							
17.2	83.31	1003	0.88	4400	16000	PH3SHD4P022***							
14.7	97.50	1130	2.07	25000	35000	PH5SJD4P022***							
14.7	97.50	1117	1.22	19500	20000	PH4SJD4P022***							
14	101.54	1279	2.87	34000	50000	PH6SJD4P022***							
12	117.14	1361	2.58	34000	50000	PH6SKD4P022***							
12	123.00	1408	1.77	25000	35000	PH5SKD4P022***							
12	123.00	1390	1.02	16200	20000	PH4SKD4P022***							
9.2	156.19	1757	2.92	42000	55000	PH7SLD4P022***							
8.9	161.25	1815	1.46	24300	35000	PH5SLD4P022***							
8.9	161.25	1794	0.78	9250	20000	PH4SLD4P022***							
8.1	176.00	1988	1.96	34000	50000	PH6SLD4P022***							
7.1	202.35	2228	2.48	42000	55000	PH7SMD4P022***							
6.9	207.69	2321	1.73	32800	50000	PH6SMD4P022***							
7.0	205.38	2279	1.23	19700	35000	PH5SMD4P022***							
5.8	248.18	2725	1.08	13800	35000	PH5SND4P022***							
5.8	246.92	2729	1.54	28100	50000	PH6SND4P022***							
5.2	276.92	3015	2.54	55000	55000	PH8SND4P022***							
5.2	276.92	2977	2.00	40700	55000	PH7SND4P022***							
4.6	207.69	3422	1.30	20600	50000	PH6SMD6P022***							
4.6	205.38	3368	0.88	#	35000	PH5SMD6P022***							

P1 2.2 kW (cont)		4P - D100LD 1430 RPM					6P - D112MD 945 RPM						
n ₂	Actual Ratio	M ₂	S _F	Overhung Load	Axial Load	Product Code	n ₂	Actual Ratio	M ₂	S _F	Overhung Load	Axial Load	Product Code
rpm	i	Nm		(max.) N	(max.) N		rpm	i	Nm		(max.) N	(max.) N	
4.3	329.23	3539	2.26	55000	55000	PH8SPD4P022***							
4.3	329.23	3494	1.77	36300	55000	PH7SPD4P022***							
3.8	246.92	4027	1.15	6950	50000	PH6SND6P022***							
3.4	276.92	4427	1.89	55000	55000	PH8SND6P022***							
3.4	276.92	4372	1.50	29600	55000	PH7SND6P022***							
2.9	329.23	5200	1.67	51400	55000	PH8SPD6P022***							
2.9	329.23	5136	1.30	18600	55000	PH7SPD6P022***							

Key

n₂ Output Speed, rpm

i Overall Ratio

M₂ Output Torque Nm, Mechanical

S_F Service Factor, Mechanical

Consult Renold Gears Technical Dept.

For details of unit designation code see page 13.

The overhung load shown above is based on the maximum motor Power being transmitted. For higher overhung loads consult Renold.



Units to ATEX approval must be selected with a minimum service factor of 1.25.

RENOLD PM Series - PH Type - Motorised - Selection Data

P1 3.0 kW		4P - D100LXD 1400 RPM					Product Code
		6P - D132SD 960 RPM					
n ₂ rpm	Actual Ratio i	M ₂ Nm	S _F	Overhung Load (max.) N	Axial Load (max.) N		
90	15.50	283	2.74	18000	20000	PH4SAD4P030***	
90	15.50	279	1.90	9000	16000	PH3SAD4P030***	
69	20.43	373	4.10	25000	35000	PH5SBD4P030***	
69	20.43	370	2.29	18000	20000	PH4SBD4P030***	
69	20.43	365	1.59	9000	16000	PH3SBD4P030***	
54	26.11	473	3.52	25000	35000	PH5SCD4P030***	
54	26.11	470	1.99	18000	20000	PH4SCD4P030***	
54	26.11	461	1.39	9000	16000	PH3SCD4P030***	
41	33.91	610	3.00	25000	35000	PH5SDD4P030***	
41	33.91	604	1.68	18000	20000	PH4SDD4P030***	
41	33.91	593	1.18	9000	16000	PH3SDD4P030***	
36	39.02	677	1.07	9000	16000	PH3SED4P030***	
36	39.02	692	1.54	18000	20000	PH4SED4P030***	
35	39.55	672	2.68	25000	35000	PH5SED4P030***	
27	51.01	919	3.36	34000	50000	PH6SFD4P030***	
28	50.38	885	1.23	18000	20000	PH4SFD4P030***	
28	50.38	864	0.91	9000	16000	PH3SFD4P030***	
28	50.53	849	2.28	25000	35000	PH5SFD4P030***	
24	57.27	1027	3.09	34000	50000	PH6SGD4P030***	
22	63.55	1079	0.78	9000	16000	PH3SGD4P030***	
21	65.63	1086	1.95	25000	35000	PH5SGD4P030***	
21	65.63	1073	1.13	18000	20000	PH4SGD4P030***	
19	75.52	1239	1.78	25000	35000	PH5SHD4P030***	
19	75.52	1225	1.03	18000	20000	PH4SHD4P030***	
17	83.11	1478	3.61	42000	55000	PH7SHD4P030***	
16	86.04	1519	2.33	34000	50000	PH6SHD4P030***	
14	97.50	1576	1.50	25000	35000	PH5SJD4P030***	
14	97.50	1556	0.87	13700	20000	PH4SJD4P030***	
16	86.04	1792	3.11	42000	55000	PH7SJD4P030***	
14	101.54	1782	2.08	34000	50000	PH6SJD4P030***	
12	117.14	1893	1.86	34000	50000	PH6SKD4P030***	
12	120.72	2116	2.76	42000	55000	PH7SKD4P030***	
11	123.00	1961	1.28	23000	35000	PH5SKD4P030***	
9	156.19	2477	2.70	55000	55000	PH8SLD4P030***	
9	156.19	2444	2.11	42000	55000	PH7SLD4P030***	
9	161.25	2528	1.05	16700	35000	PH5SLD4P030***	
8	176.00	2766	1.41	28900	50000	PH6SLD4P030***	
7	202.35	3141	2.27	55000	55000	PH8SMD4P030***	
7	202.35	3100	1.79	40300	55000	PH7SMD4P030***	

P1 3.0 kW (cont)		4P - D100LXD 1400 RPM					Product Code
		6P - D132SD 960 RPM					
n ₂ rpm	Actual Ratio i	M ₂ Nm	S _F	Overhung Load (max.) N	Axial Load (max.) N		
7	207.69	3229	1.25	23200	50000	PH6SMD4P030***	
7	205.38	3175	0.89	4350	35000	PH5SMD4P030***	
6	248.18	3791	0.78	#	35000	PH5SND4P030***	
6	246.92	3797	1.12	12200	50000	PH6SND4P030***	
5	276.92	4195	1.84	55000	55000	PH8SND4P030***	
5	276.92	4141	1.45	31800	55000	PH7SND4P030***	
5	207.69	4599	0.96	#	50000	PH6SMD6P030***	
4	329.23	4923	1.63	53400	55000	PH8SPD4P030***	
4	329.23	4861	1.28	22400	55000	PH7SPD4P030***	
4	246.92	5412	0.85	#	50000	PH6SND6P030***	
3	276.92	5949	1.40	46800	55000	PH8SND6P030***	
3	276.92	5879	1.10	8500	55000	PH7SND6P030***	
3	329.23	6989	1.24	34900	55000	PH8SPD6P030***	
3	329.23	6904	0.97	#	55000	PH7SPD6P030***	

Key

- n₂ Output Speed, rpm
- i Overall Ratio
- M₂ Output Torque Nm, Mechanical
- S_F Service Factor, Mechanical

Consult Renold Gears Technical Dept.

For details of unit designation code see page 13.

The overhung load shown above is based on the maximum motor Power being transmitted. For higher overhung loads consult Renold.



Units to ATEX approval must be selected with a minimum service factor of 1.25.

RENOLD PM Series - PH Type - Motorised - Selection Data

P1 4.0 kW		4P - D112MD 1430 RPM					6P - D132MD 955 RPM						
n ₂	Actual Ratio	M ₂	S _F	Overhung Load	Axial Load	Product Code	n ₂	Actual Ratio	M ₂	S _F	Overhung Load	Axial Load	Product Code
rpm	i	Nm		(max.) N	(max.) N		rpm	i	Nm		(max.) N	(max.) N	
92	15.50	373	3.67	25000	35000	PH5SAD4P040***	92	15.50	371	2.07	18000	20000	PH4SAD4P040***
92	15.50	366	1.44	9000	16000	PH3SAD4P040***	92	15.50	366	1.44	9000	16000	PH3SAD4P040***
70	20.43	488	3.11	25000	35000	PH5SBD4P040***	70	20.43	488	3.11	25000	35000	PH5SBD4P040***
70	20.43	485	1.74	18000	20000	PH4SBD4P040***	70	20.43	485	1.74	18000	20000	PH4SBD4P040***
70	20.43	477	1.21	9000	16000	PH3SBD4P040***	70	20.43	477	1.21	9000	16000	PH3SBD4P040***
55	26.11	620	2.67	25000	35000	PH5SCD4P040***	55	26.11	620	2.67	25000	35000	PH5SCD4P040***
55	26.11	614	1.51	18000	20000	PH4SCD4P040***	55	26.11	614	1.51	18000	20000	PH4SCD4P040***
55	26.11	603	1.05	9000	16000	PH3SCD4P040***	55	26.11	603	1.05	9000	16000	PH3SCD4P040***
42	33.91	799	2.27	25000	35000	PH5SDD4P040***	42	33.91	799	2.27	25000	35000	PH5SDD4P040***
42	33.91	790	1.28	18000	20000	PH4SDD4P040***	42	33.91	790	1.28	18000	20000	PH4SDD4P040***
42	33.91	775	0.89	8750	16000	PH3SDD4P040***	42	33.91	775	0.89	8750	16000	PH3SDD4P040***
44	32.85	788	3.39	34000	50000	PH6SDD4P040***	44	32.85	788	3.39	34000	50000	PH6SDD4P040***
37	39.02	905	1.17	18000	20000	PH4SED4P040***	37	39.02	905	1.17	18000	20000	PH4SED4P040***
37	39.02	886	0.82	6950	16000	PH3SED4P040***	37	39.02	886	0.82	6950	16000	PH3SED4P040***
36	39.55	882	2.03	25000	35000	PH5SED4P040***	36	39.55	882	2.03	25000	35000	PH5SED4P040***
35	41.28	980	2.93	34000	50000	PH6SED4P040***	35	41.28	980	2.93	34000	50000	PH6SED4P040***
28	51.01	1199	2.56	34000	50000	PH6SFD4P040***	28	51.01	1199	2.56	34000	50000	PH6SFD4P040***
28	50.38	1156	0.94	18000	20000	PH4SFD4P040***	28	50.38	1156	0.94	18000	20000	PH4SFD4P040***
28	50.53	1112	1.73	25000	35000	PH5SFD4P040***	28	50.53	1112	1.73	25000	35000	PH5SFD4P040***
25	57.27	1350	3.54	42000	55000	PH7SGD4P040***	25	57.27	1350	3.54	42000	55000	PH7SGD4P040***
25	57.27	1342	2.36	34000	50000	PH6SGD4P040***	25	57.27	1342	2.36	34000	50000	PH6SGD4P040***
22	65.63	1423	1.48	25000	35000	PH5SGD4P040***	22	65.63	1423	1.48	25000	35000	PH5SGD4P040***
22	65.63	1406	0.86	16000	20000	PH4SGD4P040***	22	65.63	1406	0.86	16000	20000	PH4SGD4P040***
19	75.52	1624	1.35	25000	35000	PH5SHD4P040***	19	75.52	1624	1.35	25000	35000	PH5SHD4P040***
19	75.52	1604	0.79	12900	20000	PH4SHD4P040***	19	75.52	1604	0.79	12900	20000	PH4SHD4P040***
17	83.11	1930	2.75	42000	55000	PH7SHD4P040***	17	83.11	1930	2.75	42000	55000	PH7SHD4P040***
17	86.04	1985	1.77	34000	50000	PH6SHD4P040***	17	86.04	1985	1.77	34000	50000	PH6SHD4P040***
15	97.50	2063	1.14	22000	35000	PH5SJD4P040***	15	97.50	2063	1.14	22000	35000	PH5SJD4P040***
14	101.54	2352	3.13	55000	55000	PH8SJD4P040***	14	101.54	2352	3.13	55000	55000	PH8SJD4P040***
14	101.54	2340	2.36	42000	55000	PH7SJD4P040***	14	101.54	2340	2.36	42000	55000	PH7SJD4P040***
14	101.54	2327	1.58	34000	50000	PH6SJD4P040***	14	101.54	2327	1.58	34000	50000	PH6SJD4P040***
12	117.14	2476	1.42	30400	50000	PH6SKD4P040***	12	117.14	2476	1.42	30400	50000	PH6SKD4P040***
12	120.72	2779	2.78	55000	55000	PH8SKD4P040***	12	120.72	2779	2.78	55000	55000	PH8SKD4P040***
12	120.72	2765	2.10	41400	55000	PH7SKD4P040***	12	120.72	2765	2.10	41400	55000	PH7SKD4P040***
12	123.00	2566	0.97	16200	35000	PH5SKD4P040***	12	123.00	2566	0.97	16200	35000	PH5SKD4P040***
9.2	156.19	3239	2.06	55000	55000	PH8SLD4P040***	9.2	156.19	3239	2.06	55000	55000	PH8SLD4P040***
9.2	156.19	3196	1.61	38300	55000	PH7SLD4P040***	9.2	156.19	3196	1.61	38300	55000	PH7SLD4P040***
8.9	161.25	3309	0.80	#	35000	PH5SLD4P040***	8.9	161.25	3309	0.80	#	35000	PH5SLD4P040***

P1 4.0 kW (cont)		4P - D112MD 1430 RPM					6P - D132MD 955 RPM						
n ₂	Actual Ratio	M ₂	S _F	Overhung Load	Axial Load	Product Code	n ₂	Actual Ratio	M ₂	S _F	Overhung Load	Axial Load	Product Code
rpm	i	Nm		(max.) N	(max.) N		rpm	i	Nm		(max.) N	(max.) N	
8.1	176.00	3616	1.08	18400	50000	PH6SLD4P040***	8.1	176.00	3616	1.08	18400	50000	PH6SLD4P040***
7.1	202.35	4107	1.73	55000	55000	PH8SMD4P040***	7.1	202.35	4107	1.73	55000	55000	PH8SMD4P040***
7.1	202.35	4054	1.37	33300	55000	PH7SMD4P040***	7.1	202.35	4054	1.37	33300	55000	PH7SMD4P040***
6.9	207.69	4220	0.95	5050	50000	PH6SMD4P040***	6.9	207.69	4220	0.95	5050	50000	PH6SMD4P040***
5.8	246.92	4964	0.85	#	50000	PH6SND4P040***	5.8	246.92	4964	0.85	#	50000	PH6SND4P040***
5.2	276.92	5483	1.40	50500	55000	PH8SND4P040***	5.2	276.92	5483	1.40	50500	55000	PH8SND4P040***
5.2	276.92	5414	1.10	16800	55000	PH7SND4P040***	5.2	276.92	5414	1.10	16800	55000	PH7SND4P040***
4.3	329.23	6438	1.24	40700	55000	PH8SPD4P040***	4.3	329.23	6438	1.24	40700	55000	PH8SPD4P040***
4.3	329.23	6356	0.97	#	55000	PH7SPD4P040***	4.3	329.23	6356	0.97	#	55000	PH7SPD4P040***
3.4	276.92	7970	1.04	25500	55000	PH8SND6P040***	3.4	276.92	7970	1.04	25500	55000	PH8SND6P040***
3.4	276.92	7875	0.82	#	55000	PH7SND6P040***	3.4	276.92	7875	0.82	#	55000	PH7SND6P040***
2.9	329.23	9367	*0.93	22800	55000	PH8SPD6P040***	2.9	329.23	9367	*0.93	22800	55000	PH8SPD6P040***

Key

n₂ Output Speed, rpm

i Overall Ratio

M₂ Output Torque Nm, Mechanical

S_F Service Factor, Mechanical

Consult Renold Gears Technical Dept.

For details of unit designation code see page 13.

The overhung load shown above is based on the maximum motor Power being transmitted. For higher overhung loads consult Renold.

* Max. Standard Plug-in Shaft Torque Nm

PH35	PH40	PH50	PH60	PH70	PH80
1045	1705	3040	4300	6090	8025

Overhung Load Capacity is that what can be applied along with the lower of either M₂ or the value stated in the table above.



Units to ATEX approval must be selected with a minimum service factor of 1.25.

RENOLD PM Series - PH Type - Motorised - Selection Data

P1 5.5 kW		4P - D132SD 1435 RPM					6P - D132MXD 955 RPM						
n ₂	Actual Ratio	M ₂	S _F	Overhung Load	Axial Load	Product Code	n ₂	Actual Ratio	M ₂	S _F	Overhung Load	Axial Load	Product Code
rpm	i	Nm		(max.) N	(max.) N		rpm	i	Nm		(max.) N	(max.) N	
93	15.50	513	2.66	25000	35000	PH5SAD4P055***	93	15.50	513	2.66	25000	35000	PH5SAD4P055***
93	15.50	509	1.51	18000	20000	PH4SAD4P055***	93	15.50	509	1.51	18000	20000	PH4SAD4P055***
93	15.50	502	1.05	9000	16000	PH3SAD4P055***	93	15.50	502	1.05	9000	16000	PH3SAD4P055***
70	20.43	671	2.26	25000	35000	PH5SBD4P055***	70	20.43	671	2.26	25000	35000	PH5SBD4P055***
70	20.43	666	1.27	18000	20000	PH4SBD4P055***	70	20.43	666	1.27	18000	20000	PH4SBD4P055***
70	20.43	655	0.88	9000	16000	PH3SBD4P055***	70	20.43	655	0.88	9000	16000	PH3SBD4P055***
67	21.33	714	3.22	34000	50000	PH6SBD4P055***	67	21.33	714	3.22	34000	50000	PH6SBD4P055***
55	26.11	851	1.94	25000	35000	PH5SCD4P055***	55	26.11	851	1.94	25000	35000	PH5SCD4P055***
55	26.11	843	1.10	18000	20000	PH4SCD4P055***	55	26.11	843	1.10	18000	20000	PH4SCD4P055***
55	26.30	873	2.83	34000	50000	PH6SCD4P055***	55	26.30	873	2.83	34000	50000	PH6SCD4P055***
42	33.91	1097	1.66	25000	35000	PH5SDD4P055***	42	33.91	1097	1.66	25000	35000	PH5SDD4P055***
42	33.91	1085	0.93	18000	20000	PH4SDD4P055***	42	33.91	1085	0.93	18000	20000	PH4SDD4P055***
44	32.85	1087	3.69	42000	55000	PH7SDD4P055***	44	32.85	1087	3.69	42000	55000	PH7SDD4P055***
44	32.85	1079	2.47	34000	50000	PH6SDD4P055***	44	32.85	1079	2.47	34000	50000	PH6SDD4P055***
37	39.02	1241	0.85	18000	20000	PH4SED4P055***	37	39.02	1241	0.85	18000	20000	PH4SED4P055***
36	39.55	1211	1.48	25000	35000	PH5SED4P055***	36	39.55	1211	1.48	25000	35000	PH5SED4P055***
35	41.28	1352	3.15	42000	55000	PH7SED4P055***	35	41.28	1352	3.15	42000	55000	PH7SED4P055***
35	41.28	1343	2.13	34000	50000	PH6SED4P055***	35	41.28	1343	2.13	34000	50000	PH6SED4P055***
28	51.01	1656	2.79	42000	55000	PH7SFD4P055***	28	51.01	1656	2.79	42000	55000	PH7SFD4P055***
28	51.01	1645	1.86	34000	50000	PH6SFD4P055***	28	51.01	1645	1.86	34000	50000	PH6SFD4P055***
28	50.53	1527	1.26	25000	35000	PH5SFD4P055***	28	50.53	1527	1.26	25000	35000	PH5SFD4P055***
25	57.27	1850	2.58	42000	55000	PH7SGD4P055***	25	57.27	1850	2.58	42000	55000	PH7SGD4P055***
25	57.27	1839	1.71	34000	50000	PH6SGD4P055***	25	57.27	1839	1.71	34000	50000	PH6SGD4P055***
22	65.63	1952	1.08	23100	35000	PH5SGD4P055***	22	65.63	1952	1.08	23100	35000	PH5SGD4P055***
19	75.52	2227	0.99	20300	35000	PH5SHD4P055***	19	75.52	2227	0.99	20300	35000	PH5SHD4P055***
17	83.11	2659	2.65	55000	55000	PH8SHD4P055***	17	83.11	2659	2.65	55000	55000	PH8SHD4P055***
17	83.11	2645	2.00	42000	55000	PH7SHD4P055***	17	83.11	2645	2.00	42000	55000	PH7SHD4P055***
17	86.04	2719	1.29	29400	50000	PH6SHD4P055***	17	86.04	2719	1.29	29400	50000	PH6SHD4P055***
15	97.50	2830	0.83	12000	35000	PH5SJD4P055***	15	97.50	2830	0.83	12000	35000	PH5SJD4P055***
14	101.54	3223	2.28	55000	55000	PH8SJD4P055***	14	101.54	3223	2.28	55000	55000	PH8SJD4P055***
14	101.54	3207	1.72	39100	55000	PH7SJD4P055***	14	101.54	3207	1.72	39100	55000	PH7SJD4P055***
14	101.54	3189	1.15	23700	50000	PH6SJD4P055***	14	101.54	3189	1.15	23700	50000	PH6SJD4P055***
12	117.14	3393	1.03	19000	50000	PH6SKD4P055***	12	117.14	3393	1.03	19000	50000	PH6SKD4P055***
12	120.72	3808	2.03	55000	55000	PH8SKD4P055***	12	120.72	3808	2.03	55000	55000	PH8SKD4P055***
12	120.72	3789	1.53	33700	55000	PH7SKD4P055***	12	120.72	3789	1.53	33700	55000	PH7SKD4P055***
9	156.19	4439	1.50	55000	55000	PH8SLD4P055***	9	156.19	4439	1.50	55000	55000	PH8SLD4P055***
9	156.19	4380	1.17	27700	55000	PH7SLD4P055***	9	156.19	4380	1.17	27700	55000	PH7SLD4P055***
8	176.00	4955	0.79	#	50000	PH6SLD4P055***	8	176.00	4955	0.79	#	50000	PH6SLD4P055***
7	202.35	5628	1.26	50400	55000	PH8SMD4P055***	7	202.35	5628	1.26	50400	55000	PH8SMD4P055***

P1 5.5 kW (cont)		4P - D132SD 1435 RPM					6P - D132MXD 955 RPM						
n ₂	Actual Ratio	M ₂	S _F	Overhung Load	Axial Load	Product Code	n ₂	Actual Ratio	M ₂	S _F	Overhung Load	Axial Load	Product Code
rpm	i	Nm		(max.) N	(max.) N		rpm	i	Nm		(max.) N	(max.) N	
7	202.35	5554	0.99	16700	55000	PH7SMD4P05***	7	202.35	5554	0.99	16700	55000	PH7SMD4P05***
5	276.92	7516	1.02	31600	55000	PH8SND4P055***	5	276.92	7516	1.02	31600	55000	PH8SND4P055***
5	276.92	7420	0.80	#	55000	PH7SND4P055***	5	276.92	7420	0.80	#	55000	PH7SND4P055***
4	329.23	8821	*0.91	2280	55000	PH8SPD4P055***	4	329.23	8821	*0.91	2280	55000	PH8SPD4P055***
3	276.92	10958	*0.76	22800	55000	PH8SND6P055***	3	276.92	10958	*0.76	22800	55000	PH8SND6P055***

Key

n₂ Output Speed, rpm

i Overall Ratio

M₂ Output Torque Nm, Mechanical

S_F Service Factor, Mechanical

Consult Renold Gears Technical Dept.

For details of unit designation code see page 13.

The overhung load shown above is based on the maximum motor Power being transmitted. For higher overhung loads consult Renold.

* Max. Standard Plug-in Shaft Torque Nm

PH35	PH40	PH50	PH60	PH70	PH80
1045	1705	3040	4300	6090	8025

Overhung Load Capacity is that what can be applied along with the lower of either M₂ or the value stated in the table above.



Units to ATEX approval must be selected with a minimum service factor of 1.25.

RENOLD PM Series - PH Type - Motorised - Selection Data

P1 7.5 kW		4P - D132SD 1435 RPM				
n ₂ rpm	Actual Ratio i	M ₂ Nm	S _F	Overhung Load (max.) N	Axial Load (max.) N	Product Code
93	15.50	701	1.95	25000	35000	PH5SAD4P075***
93	15.50	695	1.10	18000	20000	PH4SAD4P075***
86	16.60	761	2.75	34000	50000	PH6SAD4P075***
70	20.43	918	1.65	25000	35000	PH5SBD4P075***
70	20.43	909	0.93	18000	20000	PH4SBD4P075***
67	21.33	976	3.54	42000	55000	PH7SBD4P075***
67	21.33	973	2.36	34000	50000	PH6SBD4P075***
55	26.11	1163	1.42	25000	35000	PH5SCD4P075***
55	26.11	1151	0.80	18000	20000	PH4SCD4P075***
55	26.30	1198	3.07	42000	55000	PH7SCD4P075***
55	26.30	1190	2.07	34000	50000	PH6SCD4P075***
42	33.91	1498	1.21	25000	35000	PH5SDD4P075***
44	32.85	1482	2.71	42000	55000	PH7SDD4P075***
44	32.85	1472	1.81	34000	50000	PH6SDD4P075***
36	39.55	1655	1.08	25000	35000	PH5SED4P075***
35	41.28	1854	3.07	55000	55000	PH8SED4P075***
35	41.28	1844	2.31	42000	55000	PH7SED4P075***
35	41.28	1832	1.56	34000	50000	PH6SED4P075***
28	51.01	2271	2.70	55000	55000	PH8SFD4P075***
28	51.01	2258	2.05	42000	55000	PH7SFD4P075***
28	51.01	2244	1.37	33600	50000	PH6SFD4P075***
28	50.53	2085	0.92	21800	35000	PH5SFD4P075***
25	57.27	2537	2.50	55000	55000	PH8SGD4P075***
25	57.27	2523	1.89	42000	55000	PH7SGD4P075***
25	57.27	2507	1.26	30100	50000	PH6SGD4P075***
22	65.63	2665	0.79	14700	35000	PH5SGD4P075***
17	83.11	3627	1.94	55000	55000	PH8SHD4P075***
17	83.11	3607	1.47	35600	55000	PH7SHD4P075***
17	86.04	3708	0.95	16900	50000	PH6SHD4P075***
14	101.54	4395	1.67	55000	55000	PH8SJD4P075***
14	101.54	4373	1.27	29500	55000	PH7SJD4P075***
14	101.54	4348	0.85	#	50000	PH6SJD4P075***
12	120.72	5192	1.49	51300	55000	PH8SKD4P075***
12	120.72	5167	1.12	18000	55000	PH7SKD4P075***
9	156.19	6053	1.10	43900	55000	PH8SLD4P075***
9	156.19	5972	0.86	#	55000	PH7SLD4P075***
7	202.35	7675	0.92	31700	55000	PH8SMD4P075***
5	276.92	10250	*0.75	22800	55000	PH8SND4P075***

The overhung load shown above is based on the maximum motor Power being transmitted. For higher overhung loads consult Renold.

Key

- n₂ Output Speed, rpm
- i Overall Ratio
- M₂ Output Torque Nm, Mechanical
- S_F Service Factor, Mechanical
- # Consult Renold Gears Technical Dept.

For details of unit designation code see page 13.

* Max. Standard Plug-in Shaft Torque Nm

PH35	PH40	PH50	PH60	PH70	PH80
1045	1705	3040	4300	6090	8025

Overhung Load Capacity is that what can be applied along with the lower of either M₂ or the value stated in the table above.



Units to ATEX approval must be selected with a minimum service factor of 1.25.

RENOLD PM Series - PH Type - Motorised - Selection Data

P1 11.0 kW		4P - D160MD 1450 RPM				
n ₂ rpm	Actual Ratio i	M ₂ Nm	S _F	Overhung Load (max.) N	Axial Load (max.) N	Product Code
94	15.50	1020	1.33	25000	35000	PH5SAD4P110***
87	16.60	1107	2.78	42000	55000	PH7SAD4P110***
87	16.60	1104	1.88	34000	50000	PH6SAD4P110***
71	20.43	1335	1.13	25000	35000	PH5SBD4P110***
68	21.33	1421	3.21	55000	55000	PH8SBD4P110***
68	21.33	1417	2.43	42000	55000	PH7SBD4P110***
68	21.33	1413	1.62	34000	50000	PH6SBD4P110***
56	26.11	1691	0.97	25000	35000	PH5SCD4P110***
55	26.30	1744	2.79	55000	55000	PH8SCD4P110***
55	26.30	1740	2.10	42000	55000	PH7SCD4P110***
55	26.30	1728	1.42	34000	50000	PH6SCD4P110***
43	33.91	2176	0.83	20800	35000	PH5SDD4P110***
44	32.85	2165	2.45	55000	55000	PH8SDD4P110***
44	32.85	2152	1.86	42000	55000	PH7SDD4P110***
44	32.85	2138	1.25	33300	50000	PH6SDD4P110***
35	41.28	2693	2.10	55000	55000	PH8SED4P110***
35	41.28	2677	1.59	42000	55000	PH7SED4P110***
35	41.28	2660	1.07	29400	50000	PH6SED4P110***
28	51.01	3297	1.85	55000	55000	PH8SFD4P110***
28	51.01	3279	1.40	38800	55000	PH7SFD4P110***
28	51.01	3258	0.94	23200	50000	PH6SFD4P110***
25	57.27	3684	1.72	55000	55000	PH8SGD4P110***
25	57.27	3663	1.30	34500	55000	PH7SGD4P110***
25	57.27	3641	0.86	14600	50000	PH6SGD4P110***
17	83.11	5266	1.33	51200	55000	PH8SHD4P110***
17	83.11	5238	1.01	17900	55000	PH7SHD4P110***
14	101.54	6383	1.15	43000	55000	PH8SJD4P110***
14	101.54	6351	0.87	#	55000	PH7SJD4P110***
12	120.72	7540	1.02	27900	55000	PH8SKD4P110***
9	156.19	8794	*0.76	22800	55000	PH8SLD4P110***

Key

- n₂ Output Speed, rpm
- i Overall Ratio
- M₂ Output Torque Nm, Mechanical
- S_F Service Factor, Mechanical

Consult Renold Gears Technical Dept.

For details of unit designation code see page 13.

The overhung load shown above is based on the maximum motor Power being transmitted. For higher overhung loads consult Renold.

* Max. Standard Plug-in Shaft Torque Nm

PH35	PH40	PH50	PH60	PH70	PH80
1045	1705	3040	4300	6090	8025

Overhung Load Capacity is that what can be applied along with the lower of either M₂ or the value stated in the table above.



IMPORTANT

Units to ATEX approval must be selected with a minimum service factor of 1.25.

RENOLD PM Series - PH Type - Motorised - Selection Data

P1		15.0 kW		4P - D160LD 1460 RPM		
n ₂ rpm	Actual Ratio i	M ₂ Nm	S _F	Overhung Load (max.) N	Axial Load (max.) N	Product Code
94	15.50	1385	0.98	25000	35000	PH5SAD4P150***
88	16.60	1503	2.71	55000	55000	PH8SAD4P150***
88	16.60	1500	2.04	42000	55000	PH7SAD4P150***
88	16.60	1496	1.39	34000	50000	PH6SAD4P150***
71	20.43	1810	0.83	24300	35000	PH5SBD4P150***
68	21.33	2048	2.36	55000	55000	PH8SBD4P150***
68	21.33	1919	1.79	42000	55000	PH7SBD4P150***
68	21.33	1914	1.20	34000	50000	PH6SBD4P150***
56	26.30	2363	2.06	55000	55000	PH8SCD4P150***
56	26.30	2357	1.55	42000	55000	PH7SCD4P150***
56	26.30	2341	1.05	31600	50000	PH6SCD4P150***
44	32.85	2933	1.80	55000	55000	PH8SDD4P150***
44	32.85	2915	1.37	40000	55000	PH7SDD4P150***
44	32.85	2915	0.92	24900	50000	PH6SDD4P150***
35	41.28	3648	1.55	55000	55000	PH8SED4P150***
35	41.28	3627	1.17	35900	55000	PH7SED4P150***
35	41.28	3603	0.79	17500	50000	PH6SED4P150***
29	51.01	4467	1.36	55000	55000	PH8SFD4P150***
29	51.01	4442	1.04	29300	55000	PH7SFD4P150***
25	57.27	4991	1.26	52500	55000	PH8SGD4P150***
25	57.27	4963	0.96	20200	55000	PH7SGD4P150***
18	83.11	7135	0.98	34100	55000	PH8SHD4P150***
14	101.54	8648	*0.85	22800	55000	PH8SJD4P150***
12	120.72	10213	*0.75	22800	55000	PH8SKD4P150***

The overhung load shown above is based on the maximum motor Power being transmitted. For higher overhung loads consult Renold.

Key

- n₂ Output Speed, rpm
- i Overall Ratio
- M₂ Output Torque Nm, Mechanical
- S_F Service Factor, Mechanical

For details of unit designation code see page 13.

* Max. Standard Plug-in Shaft Torque Nm

PH35	PH40	PH50	PH60	PH70	PH80
1045	1705	3040	4300	6090	8025

Overhung Load Capacity is that what can be applied along with the lower of either M₂ or the value stated in the table above.



Units to ATEX approval must be selected with a minimum service factor of 1.25.

P1		18.5 kW			4P - D180MD 1470 RPM		
n ₂ rpm	Actual Ratio i	M ₂ Nm	S _F	Overhung Load (max.) N	Axial Load (max.) N	Product Code	
89	16.60	1841	2.21	55000	55000	PH8SAD4P185***	
89	16.60	1837	1.66	42000	55000	PH7SAD4P185***	
89	16.60	1832	1.13	34000	50000	PH6SAD4P185***	
69	21.33	2357	1.92	55000	55000	PH8SBD4P185***	
69	21.33	2352	1.46	42000	55000	PH7SBD4P185***	
69	21.33	2345	0.97	32900	50000	PH6SBD4P185***	
56	26.30	2895	1.67	55000	55000	PH8SCD4P185***	
56	26.30	2888	1.26	40300	55000	PH7SCD4P185***	
56	26.30	2868	0.85	25900	50000	PH6SCD4P185***	
45	32.85	3594	1.47	55000	55000	PH8SDD4P185***	
45	32.85	3572	1.11	34900	55000	PH7SDD4P185***	
36	41.28	4470	1.26	55000	55000	PH8SED4P185***	
36	41.28	4444	0.95	28500	55000	PH7SED4P185***	
29	51.01	5474	1.11	51000	55000	PH8SFD4P185***	
29	51.01	5442	0.84	17300	55000	PH7SFD4P185***	
26	57.27	6115	1.03	43000	55000	PH8SGD4P185***	
18	83.11	8740	*0.80	22800	55000	PH8SHD4P185***	

The overhung load shown above is based on the maximum motor Power being transmitted. For higher overhung loads consult Renold.

Key

- n₂ Output Speed, rpm
- i Overall Ratio
- M₂ Output Torque Nm, Mechanical
- S_F Service Factor, Mechanical

For details of unit designation code see page 13.



Units to ATEX approval must be selected with a minimum service factor of 1.25.

RENOLD PM Series - PH Type - Motorised - Selection Data

P1 22.0 kW		4P - D180LD 1465 RPM				
n ₂ rpm	Actual Ratio i	M ₂ Nm	S _F	Overhung Load (max.) N	Axial Load (max.) N	Product Code
88	16.60	2197	1.85	55000	55000	PH8SAD4P220***
88	16.60	2192	1.39	42000	55000	PH7SAD4P220***
88	16.60	2187	0.95	33800	50000	PH6SAD4P220***
69	21.33	2813	1.61	55000	55000	PH8SBD4P220***
69	21.33	2806	1.22	41900	55000	PH7SBD4P220***
69	21.33	2798	0.82	28600	50000	PH6SBD4P220***
56	26.30	3454	1.41	55000	55000	PH8SCD4P220***
56	26.30	3446	1.06	36200	55000	PH7SCD4P220***
45	32.85	4287	1.23	55000	55000	PH8SDD4P220***
45	32.85	4262	0.94	28200	55000	PH7SDD4P220***
35	41.28	5333	1.06	51300	55000	PH8SED4P220***
35	41.28	5302	0.80	18100	55000	PH7SED4P220***
29	51.01	6531	0.93	42300	55000	PH8SFD4P220***
26	57.27	7296	0.87	30300	55000	PH8SGD4P220***

Key

- n₂ Output Speed, rpm
- i Overall Ratio
- M₂ Output Torque Nm, Mechanical
- S_F Service Factor, Mechanical

For details of unit designation code see page 13.

The overhung load shown above is based on the maximum motor Power being transmitted. For higher overhung loads consult Renold.

P1 30.0 kW		4P - D200LD 1480 RPM				
n ₂ rpm	Actual Ratio i	M ₂ Nm	S _F	Overhung Load (max.) N	Axial Load (max.) N	Product Code
89	16.60	2967	1.37	55000	55000	PH8SAD4P300***
89	16.60	2960	1.03	40500	55000	PH7SAD4P300***
69	21.33	3797	1.19	55000	55000	PH8SBD4P300***
69	21.33	3788	0.90	35200	55000	PH7SBD4P300***
56	26.30	4663	1.04	54700	55000	PH8SCD4P300***
45	32.85	5790	0.91	45400	55000	PH8SDD4P300***

Overhung Load Capacity is that what can be applied along with the lower of either M₂ or the value stated in the table above.

* Max. Standard Plug-in Shaft Torque Nm

PH35	PH40	PH50	PH60	PH70	PH80
1045	1705	3040	4300	6090	8025

Overhung Load Capacity is that what can be applied along with the lower of either M₂ or the value stated in the table above.

Consult Renold Gears Technical Dept.

Notes :

1. Maximum torques stated apply for uniform loading applications (Starts/Hr <=5)
2. For applications with combinations of high torques, overhung loads, or nos. of starts, consult Renold Gears Technical Dept.
3. For torques higher than the stated maximum, consult Renold Gears technical dept. High Tensile Steel output shaft must be specified.



Units to ATEX approval must be selected with a minimum service factor of 1.25.

RENOLD PM Series - PH Type - Motorised Unit - Dimensions

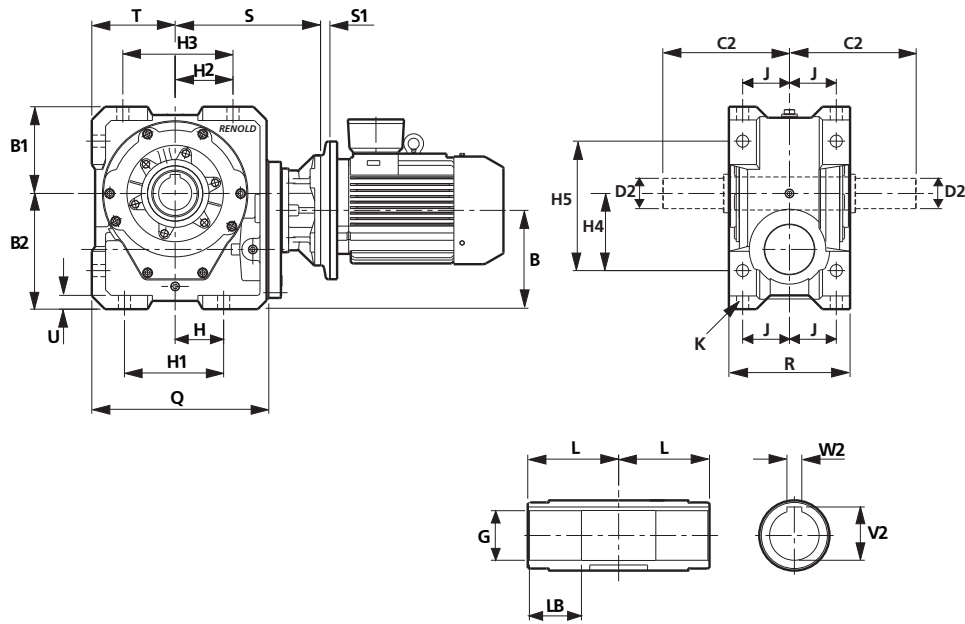

OUTPUT SHAFT
DETAILS

PM Series - PH Motorised

UNIT REF	B	B1	B2	H	H1	H2	H3	H4	H5
PH35	162.0	140.0	180	60	135	85	160	120	205
PH40	179.3	157.5	210	88	180	105	200	140	235
PH50	183.9	195.0	240	88	180	125	230	160	280
PH60	239.6	225.0	280	120	235	145	270	190	340
PH70	269.2	255.5	335	140	290	160	310	240	412
PH80	278.8	280.0	370	140	310	170	340	256	460

UNIT REF	J	K	Q	R	S	T	U
PH35	75	17.0	274	186	238	130	25
PH40	85	21.5	321	220	264	151	25
PH50	100	21.5	365	250	284	175	30
PH60	125	25.5	418	305	338	200	35
PH70	150	25.5	458	360	353	225	35
PH80	150	25.5	503	360	377	246	35

UNIT REF	S1							
	D80D	D90D	D100D	D112D	D132D	D160D	D180D	D200D
PH35	0	0	11	11	30	-	-	-
PH40	0	0	11	11	30	-	-	-
PH50	0	0	11	11	30	41	-	-
PH60	-	-	0	0	22	30	30	-
PH70	-	-	0	0	22	30	30	30
PH80	-	-	0	0	22	30	30	30

Output Sleeve

UNIT REF	G	L	LB	V2	W2
PH35	50F7	103	55	53.8	14Js9
PH40	60F7	110	65	64.4	18Js9
PH50	70F7	130	70	74.9	20Js9
PH60	90F7	155	90	95.4	25Js9
PH70	100F7	174	115	106.4	28Js9
PH80	100F7	174	115	106.4	28Js9

Plug-in Output Shaft

UNIT REF	C2	D2
PH35	220	45k6
PH40	230	55m6
PH50	280	65m6
PH60	305	75m6
PH70	355	85m6
PH80	355	95m6

RENOLD PM Series - PH Type - Motorised Unit - Dimensions

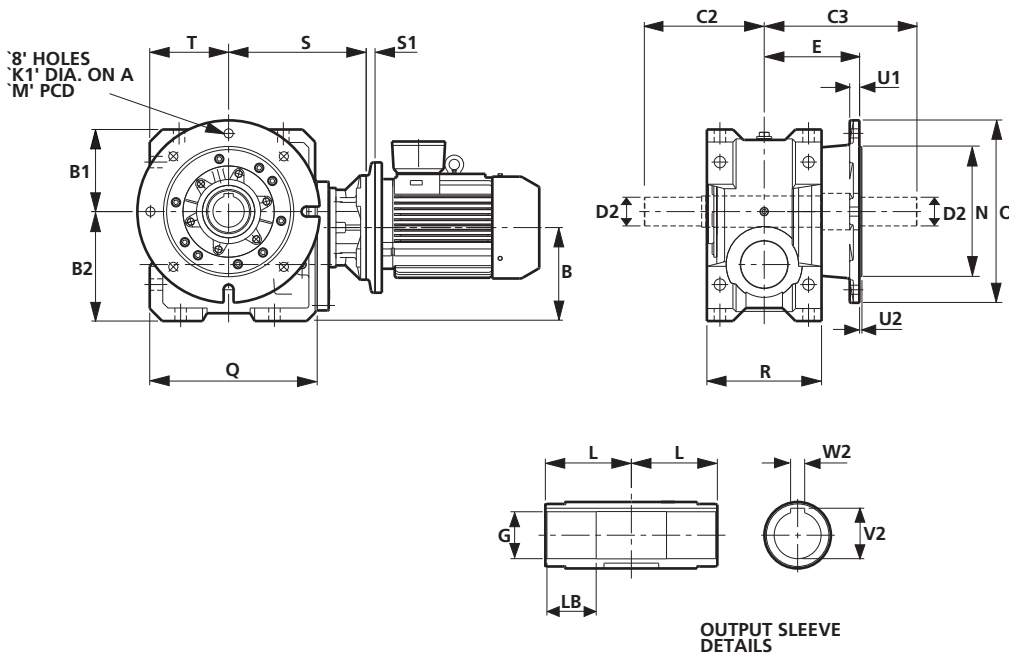

PM Series - PH Motorised - (Horizontal Flange Mounted)

UNIT REF	B	B1	B2	E	K1	M	N	O
PH35	162.0	140.0	180	154	13.5	265	230h8	300
PH40	179.3	157.5	210	183	17.5	300	250h8	350
PH50	183.9	195.0	240	197	17.5	350	300h8	400
PH60	239.6	225.0	280	215	17.5	400	350h8	450
PH70	269.0	255.5	335	248	17.5	500	450h8	550
PH80	278.8	280.0	370	248	17.5	500	450h8	550

UNIT REF	Q	R	S	T	U1	U2
PH35	274	186	238	130	13	4
PH40	321	220	264	151	19	5
PH50	365	250	284	175	19	5
PH60	418	305	338	200	19	5
PH70	458	360	353	225	24	5
PH80	503	360	377	246	24	5

UNIT REF	S1							
	D80D	D90D	D100D	D112D	D132D	D160D	D180D	D200D
PH35	0	0	11	11	30	-	-	-
PH40	0	0	11	11	30	-	-	-
PH50	0	0	11	11	30	41	-	-
PH60	-	-	0	0	22	30	30	30
PH70	-	-	0	0	22	30	30	30
PH80	-	-	0	0	22	30	30	30

Output Sleeve

UNIT REF	G	L	LB	V2	W2
PH35	50F7	103	55	53.8	14Js9
PH40	60F7	110	65	64.4	18Js9
PH50	70F7	130	70	74.9	20Js9
PH60	90F7	155	90	95.4	25Js9
PH70	100F7	174	115	106.4	28Js9
PH80	100F7	174	115	106.4	28Js9

Plug-in Output Shaft

UNIT REF	C2	C3	D2
PH35	220	264	45k6
PH40	230	293	55m6
PH50	280	337	65m6
PH60	305	355	75m6
PH70	355	418	85m6
PH80	355	418	95m6

RENOLD PM Series - PH Type - Motorised Unit - Dimensions

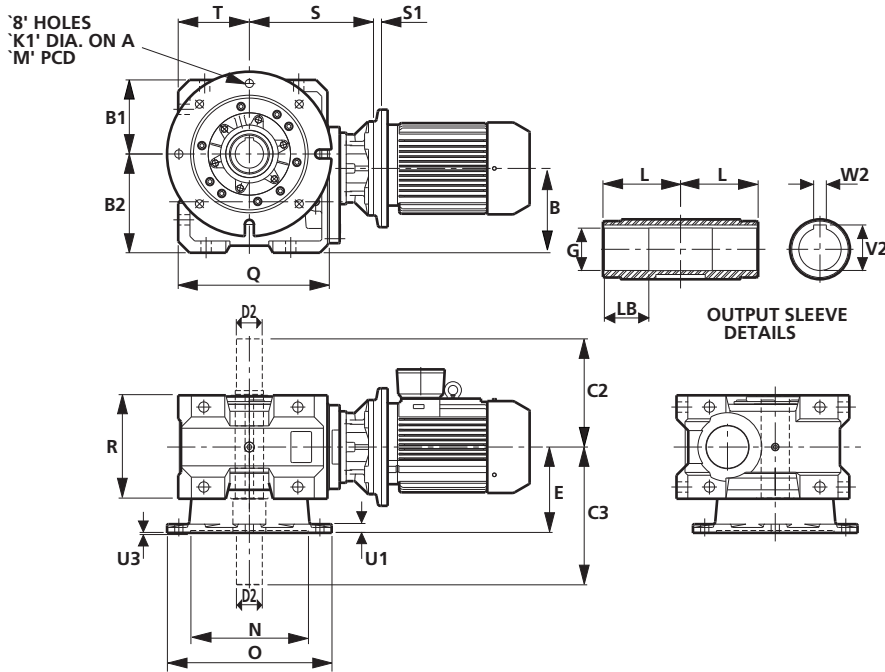

PM Series - PH Motorised - (Vertical Skirt)

UNIT REF	B	B1	B2	E	K1	M	N	O
PH35	162.0	140.0	180	154	13.5	265	230H8	300
PH40	179.3	157.5	210	183	17.5	300	250H8	350
PH50	183.9	195.0	240	197	17.5	350	300H8	400
PH60	239.6	225.0	280	215	17.5	400	350H8	450
PH70	269.0	255.5	335	248	17.5	500	450H8	550
PH80	278.8	280.0	370	248	17.5	500	450H8	550

UNIT REF	Q	R	S	T	U1	U3
PH35	274	186	238	240	13	5
PH40	321	220	264	266	19	6
PH50	365	250	284	286	19	6
PH60	418	305	338	339	19	6
PH70	458	360	353	354	24	6
PH80	503	360	377	378	24	6

UNIT REF	S1							
	D80D	D90D	D100D	D112D	D132D	D160D	D180D	D200D
PH35	0	0	11	11	30	-	-	-
PH40	0	0	11	11	30	-	-	-
PH50	0	0	11	11	30	41	-	-
PH60	-	-	0	0	22	30	30	30
PH70	-	-	0	0	22	30	30	30
PH80	-	-	0	0	22	30	30	30

Output Sleeve

UNIT REF	G	L	LB	V2	W2
PH35	50F7	103	55	53.8	14Js9
PH40	60F7	110	65	64.4	18Js9
PH50	70F7	130	70	74.9	20Js9
PH60	90F7	155	90	95.4	25Js9
PH70	100F7	174	115	106.4	28Js9
PH80	100F7	174	115	106.4	28Js9

Plug-in Output Shaft

UNIT REF	C2	C3	D2
PH35	220	264	45k6
PH40	230	293	55m6
PH50	280	337	65m6
PH60	305	355	75m6
PH70	355	418	85m6
PH80	355	418	95m6

RENOLD PM Series - PH Type - Output Shaft Dimensions

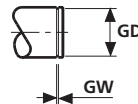
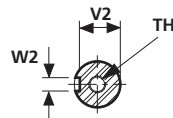
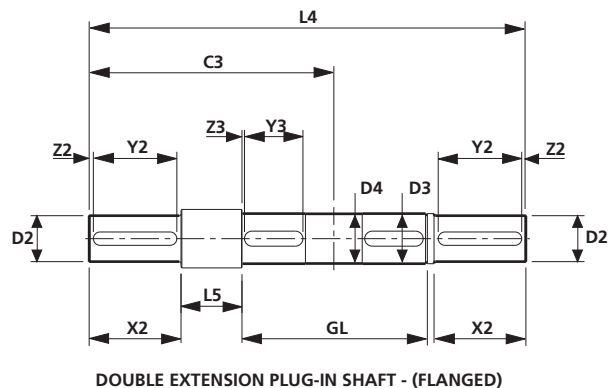
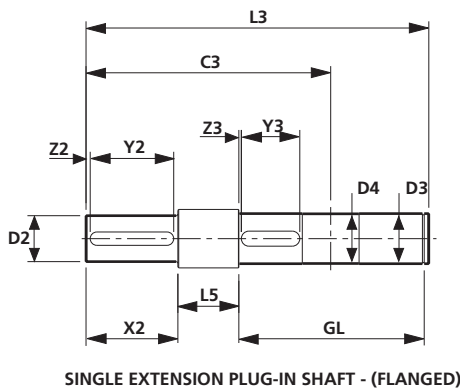
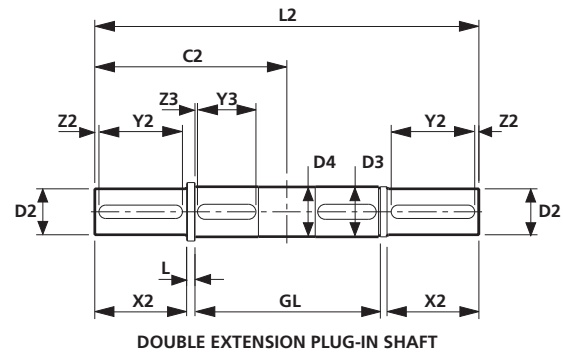
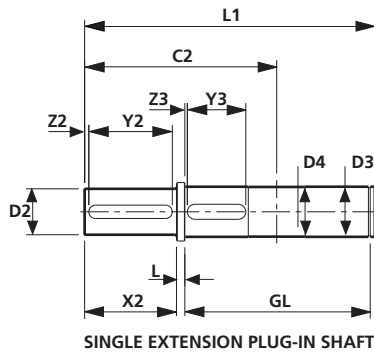

EXTENSION KEYWAY DETAILS CIRCLIP GROOVE DETAILS

Plug-in Shafts

UNIT REF	C2	C3	L	L1	L2	L3	L4	L5	GD	GL	GW
PW35	220	264	7	330.5	440	374.5	484	51	47.00	207.90	2.29
						46.75			46.75		2.15
PW40	230	293	10	347.5	460	410.5	523	73	57.00	222.15	2.29
						56.70			56.70		2.15
PW50	280	337	10	418.5	560	475.5	617	67	67.00	262.65	2.79
						66.70			66.70		2.65
PW60	305	355	10	469.5	610	519.5	660	60	86.50	313.15	3.33
						86.15			86.15		3.15
PW70	355	418	11	538.5	710	601.5	773	74	96.50	351.15	3.33
						96.15			96.15		3.15
PW80	355	418	11	538.5	710	601.5	773	74	96.50	351.15	3.33
						96.15			96.15		3.15

UNIT REF	D2	V2	W2	X2	Y2	Z2	TH	D3	Y3	Z3	D4
PW35	45k6	39.50	14P9	110	100	5	M16x36	50h6	63	3	46
PW40	55m6	49.00	16P9	110	100	5	M20x42	60h6	70	3	56
PW50	65m6	58.00	18P9	140	125	5	M20x42	70h6	90	2	66
PW60	75m6	67.50	20P9	140	125	5	M20x42	90h6	110	3	86
PW70	85m6	76.00	22P9	170	160	5	M20x42	100h6	125	3	96
PW80	95m6	86.00	25P9	170	160	5	M24x50	100h6	125	3	96

PM SERIES PH - HELICAL/WORM

OUTPUT Overhung Load Capacities @ 1500 RPM / Nominal Input Speed

Table 5

Ratio	Output Speed	Gear Unit Size					
		PH35	PH40	PH50	PH60	PH70	PH80
16	94	9000	18000	25000	34000	40100	55000
20	75	9000	18000	25000	33300	37800	55000
25	60	9000	18000	25000	31400	35200	52400
32	47	9000	18000	24500	29200	32600	49200
40	38	9000	18000	24700	27500	30300	46500
50	30	8800	18000	23600	25600	27500	43000
63	24	8050	18000	21900	24000	25300	40000
80	19	7150	18000	20900	19700	19000	32600
100	15	5900	16900	19300	19900	14900	27900
125	12	4850	15900	17400	17900	13100	22100
160	9	6550	16000	15300	12000	20700	36300
200	8	5350	16000	13100	8300	16800	33300
250	6	4350	16000	10500	2350	6900	23100
320	5	-	-	-	-	#	17400

- based on Gear Unit transmitting Mechanical Rating

Consult Renold Gears Technical Dept.

PM SERIES PH - HELICAL/WORM

OUTPUT Axial Load Capacities

Table 6

Ratio	Output Speed	Gear Unit Size					
		PH35	PH40	PH50	PH60	PH70	PH80
16	94	16000	20000	35000	50000	55000	55000
20	75	16000	20000	35000	50000	55000	55000
25	60	16000	20000	35000	50000	55000	55000
32	47	16000	20000	35000	50000	55000	55000
40	38	16000	20000	35000	50000	55000	55000
50	30	16000	20000	35000	50000	55000	55000
63	24	16000	20000	35000	50000	55000	55000
80	19	16000	20000	35000	50000	55000	55000
100	15	16000	20000	35000	50000	55000	55000
125	12	16000	20000	35000	50000	55000	55000
160	9	16000	20000	35000	50000	55000	55000
200	8	16000	20000	35000	50000	55000	55000
250	6	16000	20000	35000	50000	55000	55000
320	5	16000	20000	35000	50000	55000	55000

- based on Gear Unit transmitting Mechanical Rating

RENOLD PM Series - PH Type - Exact Ratio**PM SERIES PH - HELICAL/WORM
Actual Ratios**

PH35					
Nominal Ratio	Pinion	Wheel	Worm	Wheel	Overall Ratio
16	51	51	2	31	15.50
20	44	58	2	31	20.43
25	38	64	2	31	26.11
32	32	70	2	31	33.91
40	29	73	2	31	39.02
50	24	78	2	31	50.38
63	20	82	2	31	63.55
80	16	86	2	31	83.31
100	13	89	2	31	106.12
125	11	91	2	31	128.23
160	16	86	1	30	161.25
200	13	89	1	30	205.38
250	11	91	1	30	248.18

PH40					
Nominal Ratio	Pinion	Wheel	Worm	Wheel	Overall Ratio
16	51	51	2	31	15.50
20	44	58	2	31	20.43
25	38	64	2	31	26.11
32	32	70	2	31	33.91
40	29	73	2	31	39.02
50	24	78	2	31	50.38
63	32	70	1	30	65.63
80	29	73	1	30	75.52
100	24	78	1	30	97.50
125	20	82	1	30	123.00
160	16	86	1	30	161.25
200	13	89	1	30	205.38
250	11	91	1	30	248.18

PH50					
Nominal Ratio	Pinion	Wheel	Worm	Wheel	Overall Ratio
16	51	51	2	31	15.50
20	44	58	2	31	20.43
25	38	64	2	31	26.11
32	32	70	2	31	33.91
40	44	58	1	30	39.55
50	38	64	1	30	50.53
63	32	70	1	30	65.63
80	29	73	1	30	75.52
100	24	78	1	30	97.50
125	20	82	1	30	123.00
160	16	86	1	30	161.25
200	13	89	1	30	205.38
250	11	91	1	30	248.18

PH60					
Nominal Ratio	Pinion	Wheel	Worm	Wheel	Overall Ratio
16	38	43	3	44	16.60
20	33	48	3	44	21.33
25	29	52	3	44	26.30
32	25	56	3	44	32.85
40	27	76	3	44	41.28
50	23	80	3	44	51.01
63	21	82	3	44	57.27
80	15	88	3	44	86.04
100	13	90	3	44	101.54
125	21	82	1	30	117.14
160	15	88	1	30	176.00
200	13	90	1	30	207.69
250	13	107	1	30	246.92

PH70					
Nominal Ratio	Pinion	Wheel	Worm	Wheel	Overall Ratio
16	38	43	3	44	16.60
20	33	48	3	44	21.33
25	29	52	3	44	26.30
32	25	56	3	44	32.85
40	27	76	3	44	41.28
50	23	80	3	44	51.01
63	21	82	3	44	57.27
80	21	119	3	44	83.11
100	15	88	3	44	86.04
125	13	107	3	44	120.72
160	21	82	1	40	156.19
200	17	86	1	40	202.35
250	13	90	1	40	276.92
320	13	107	1	40	329.23

PH80					
Nominal Ratio	Pinion	Wheel	Worm	Wheel	Overall Ratio
16	38	43	3	44	16.60
20	33	48	3	44	21.33
25	29	52	3	44	26.30
32	25	56	3	44	32.85
40	27	76	3	44	41.28
50	23	80	3	44	51.01
63	21	82	3	44	57.27
80	21	119	3	44	83.11
100	15	88	3	44	86.04
125	13	107	3	44	120.72
160	21	82	1	40	156.19
200	17	86	1	40	202.35
250	13	90	1	40	276.92
320	13	107	1	40	329.23

RENOLD PM Series - PH Type - Selection Data

Nominal ratio: 16/1

Input rpm	Nominal Output rpm	Product Code Actual Ratio Overall Ratio	PH3REDXXXSA***	PH4REDXXXSA***	PH5REDXXXSA***	PH6REDXXXSA***	PH7REDXXXSA***	PH8REDXXXSA***
			Helical 51/51 Worm 2/31	Helical 51/51 Worm 2/31	Helical 51/51 Worm 2/31	Helical 38/43 Worm 3/44	Helical 38/43 Worm 3/44	Helical 38/43 Worm 3/44
			15.50	15.50	15.50	16.60	16.60	16.60
1800	113	Actual Output Speed, rpm	116	116	116	108.4	108.4	108.4
		Input kW, Thermal	6.87	10.5	18.7	29.8	43.2	59.4
		Output Torque Nm, Thermal	505	786	1413	2421	3522	4858
		Input kW, Mechanical	6.50	9.35	16.7	23.5	35.2	49.2
		Output Torque Nm, Mechanical	478	697	1254	1912	2873	4022
		Efficiency %	89.4	90.7	91.6	92.3	92.6	92.9
1500	93.8	Actual Output Speed, rpm	96.8	96.8	96.8	90.4	90.4	90.4
		Input kW, Thermal	6.38	9.79	17.4	27.7	40.1	55.3
		Output Torque Nm, Thermal	559	871	1565	2686	3906	5410
		Input kW, Mechanical	5.88	8.45	14.8	21.0	31.0	43.5
		Output Torque Nm, Mechanical	515	752	1339	2037	3020	4258
		Efficiency %	88.8	90.2	91.1	91.8	92.2	92.6
1200	75.0	Actual Output Speed, rpm	77.4	77.4	77.4	72.3	72.3	72.3
		Input kW, Thermal	5.84	8.95	15.9	25.3	36.6	50.5
		Output Torque Nm, Thermal	634	988	1775	3047	4432	6135
		Input kW, Mechanical	5.18	7.42	13.1	18.6	27.7	38.4
		Output Torque Nm, Mechanical	562	819	1469	2238	3351	4663
		Efficiency %	87.9	89.4	90.5	91.2	91.7	92.0
1000	62.5	Actual Output Speed, rpm	64.5	64.5	64.5	60.2	60.2	60.2
		Input kW, Thermal	5.44	8.34	14.8	23.5	34.0	46.9
		Output Torque Nm, Thermal	703	1097	1968	3378	4914	6808
		Input kW, Mechanical	4.59	6.59	11.6	16.6	24.7	34.4
		Output Torque Nm, Mechanical	592	866	1552	2381	3577	5000
		Efficiency %	87.2	88.8	89.9	90.7	91.2	91.6
750	46.9	Actual Output Speed, rpm	48.4	48.4	48.4	45.2	45.2	45.2
		Input kW, Thermal	4.89	7.49	13.2	21.0	30.3	41.8
		Output Torque Nm, Thermal	832	1300	2326	3990	5789	8020
		Input kW, Mechanical	3.89	5.56	9.85	13.9	20.7	28.8
		Output Torque Nm, Mechanical	660	963	1730	2648	3955	5523
		Efficiency %	86.1	87.8	89.0	89.9	90.4	90.8
500	31.3	Actual Output Speed, rpm	32.3	32.3	32.3	30.1	30.1	30.1
		Input kW, Thermal	4.26	6.53	11.5	18.2	26.1	35.8
		Output Torque Nm, Thermal	1066	1672	2974	5113	7373	10158
		Input kW, Mechanical	3.01	4.27	7.25	10.7	16.1	22.3
		Output Torque Nm, Mechanical	752	1093	1881	3007	4536	6333
		Efficiency %	84.4	86.4	87.6	88.6	89.1	89.5
250	15.6	Actual Output Speed, rpm	16.1	16.1	16.1	15.1	15.1	15.1
		Input kW, Thermal	3.49	5.34	9.26	14.6	20.8	28.3
		Output Torque Nm, Thermal	1689	2657	4684	8001	11464	15669
		Input kW, Mechanical	1.87	2.18	3.69	6.29	9.96	13.9
		Output Torque Nm, Mechanical	903	1083	1864	3448	5489	7717
		Efficiency %	81.8	84.0	85.3	86.4	86.9	87.3

For details of unit designation code see page 13.



Units to ATEX approval must be selected with a minimum service factor of 1.25.

RENOLD PM Series - PH Type - Selection Data

Nominal ratio: 20/1

Input rpm	Nominal Output rpm	Product Code Actual Ratio Overall Ratio	PH3REDXXXSB***	PH4REDXXXSB***	PH5REDXXXSB***	PH6REDXXXSB***	PH7REDXXXSB***	PH8REDXXXSB***
			Helical 44/58 Worm 2/31	Helical 44/58 Worm 2/31	Helical 44/58 Worm 2/31	Helical 33/48 Worm 3/44	Helical 33/48 Worm 3/44	Helical 33/48 Worm 3/44
			20.43	20.43	20.43	21.33	21.33	21.33
1800	90.0	Actual Output Speed, rpm	88.1	88.1	88.1	84.4	84.4	84.4
		Input kW, Thermal	6.15	9.42	16.7	27.1	39.3	54.2
		Output Torque Nm, Thermal	589	918	1650	2811	4094	5665
		Input kW, Mechanical	5.60	8.05	14.1	20.5	30.2	42.0
		Output Torque Nm, Mechanical	537	783	1394	2127	3146	4392
		Efficiency %	88.4	89.9	90.9	91.7	92.1	92.4
1500	75.0	Actual Output Speed, rpm	73.4	73.4	73.4	70.3	70.3	70.3
		Input kW, Thermal	5.72	8.76	15.6	25.2	36.5	50.4
		Output Torque Nm, Thermal	652	1019	1829	3120	4544	6294
		Input kW, Mechanical	5.00	7.16	12.7	18.5	27.6	38.2
		Output Torque Nm, Mechanical	571	832	1496	2288	3432	4768
		Efficiency %	87.7	89.3	90.3	91.2	91.7	92.0
1200	60.0	Actual Output Speed, rpm	58.7	58.7	58.7	56.3	56.3	56.3
		Input kW, Thermal	5.25	8.05	14.2	23.0	33.3	46.0
		Output Torque Nm, Thermal	743	1159	2078	3536	5143	7135
		Input kW, Mechanical	4.37	6.27	11.0	16.1	24.0	33.3
		Output Torque Nm, Mechanical	618	903	1607	2469	3712	5170
		Efficiency %	86.9	88.5	89.6	90.6	91.0	91.4
1000	50.0	Actual Output Speed, rpm	48.9	48.9	48.9	46.9	46.9	46.9
		Input kW, Thermal	4.91	7.53	13.3	21.5	31.0	42.7
		Output Torque Nm, Thermal	826	1291	2310	3941	5714	7904
		Input kW, Mechanical	3.91	5.60	9.92	14.3	21.4	29.8
		Output Torque Nm, Mechanical	657	959	1722	2629	3946	5515
		Efficiency %	86.1	87.9	89.1	90.0	90.5	90.9
750	37.5	Actual Output Speed, rpm	36.7	36.7	36.7	35.2	35.2	35.2
		Input kW, Thermal	4.45	6.81	12.0	19.3	27.8	38.1
		Output Torque Nm, Thermal	984	1540	2745	4675	6764	9322
		Input kW, Mechanical	3.27	4.67	8.22	12.0	18.0	24.8
		Output Torque Nm, Mechanical	723	1054	1884	2912	4374	6079
		Efficiency %	85.0	86.9	88.1	89.2	89.6	90.1
500	25.0	Actual Output Speed, rpm	24.5	24.5	24.5	23.4	23.4	23.4
		Input kW, Thermal	3.91	5.99	10.5	16.8	24.1	32.9
		Output Torque Nm, Thermal	1275	2002	3548	6017	8680	11902
		Input kW, Mechanical	2.50	3.26	5.53	9.12	13.6	19.1
		Output Torque Nm, Mechanical	816	1089	1874	3266	4911	6906
		Efficiency %	83.4	85.4	86.7	87.9	88.4	88.8
250	12.5	Actual Output Speed, rpm	12.2	12.2	12.2	11.7	11.7	11.7
		Input kW, Thermal	3.26	4.98	8.61	13.8	19.5	26.5
		Output Torque Nm, Thermal	2049	3228	5672	9639	13700	18703
		Input kW, Mechanical	1.55	1.67	2.83	5.02	8.15	11.8
		Output Torque Nm, Mechanical	974	1079	1857	3506	5726	8340
		Efficiency %	80.7	83.1	84.3	85.7	86.2	86.6

For details of unit designation code see page 13.



Units to ATEX approval must be selected with a minimum service factor of 1.25.

RENOLD PM Series - PH Type - Selection Data

Nominal ratio: 25/1

Input rpm	Nominal Output rpm	Product Code Actual Ratio Overall Ratio	PH3REDXXXSC***	PH4REDXXXSC***	PH5REDXXXSC***	PH6REDXXXSC***	PH7REDXXXSC***	PH8REDXXXSC***
			Helical 38/64 Worm 2/31	Helical 38/64 Worm 2/31	Helical 38/64 Worm 2/31	Helical 29/52 Worm 3/44	Helical 29/52 Worm 3/44	Helical 29/52 Worm 3/44
			26.11	26.11	26.11	26.30	26.30	26.30
1800	72.0	Actual Output Speed, rpm	68.9	68.9	68.9	68.4	68.4	68.4
		Input kW, Thermal	5.58	8.55	15.2	24.3	35.2	48.5
		Output Torque Nm, Thermal	676	1055	1895	3085	4488	6210
		Input kW, Mechanical	4.79	6.86	12.2	17.4	26.1	36.3
		Output Torque Nm, Mechanical	580	845	1524	2205	3322	4643
		Efficiency %	87.5	89.1	90.1	91.0	91.4	91.8
1500	60.0	Actual Output Speed, rpm	57.4	57.4	57.4	57.0	57.0	57.0
		Input kW, Thermal	5.21	7.98	14.1	22.6	32.7	45.1
		Output Torque Nm, Thermal	751	1173	2103	3420	4976	6893
		Input kW, Mechanical	4.32	6.19	10.9	15.6	23.2	32.3
		Output Torque Nm, Mechanical	623	910	1620	2354	3535	4939
		Efficiency %	86.8	88.4	89.6	90.4	90.9	91.3
1200	48.0	Actual Output Speed, rpm	46.0	46.0	46.0	45.6	45.6	45.6
		Input kW, Thermal	4.80	7.36	13.0	20.7	29.9	41.2
		Output Torque Nm, Thermal	857	1340	2397	3890	5644	7819
		Input kW, Mechanical	3.77	5.38	9.55	13.6	20.3	28.2
		Output Torque Nm, Mechanical	672	981	1762	2562	3832	5348
		Efficiency %	85.9	87.7	88.8	89.8	90.2	90.7
1000	40.0	Actual Output Speed, rpm	38.3	38.3	38.3	38.0	38.0	38.0
		Input kW, Thermal	4.51	6.91	12.2	19.4	27.9	38.4
		Output Torque Nm, Thermal	958	1500	2675	4346	6285	8688
		Input kW, Mechanical	3.36	4.80	8.52	12.1	18.1	25.1
		Output Torque Nm, Mechanical	714	1041	1874	2715	4073	5690
		Efficiency %	85.1	87.0	88.2	89.2	89.7	90.1
750	30.0	Actual Output Speed, rpm	28.7	28.7	28.7	28.5	28.5	28.5
		Input kW, Thermal	4.11	6.29	11.0	17.6	25.2	34.5
		Output Torque Nm, Thermal	1148	1802	3201	5204	7494	10305
		Input kW, Mechanical	2.79	3.82	6.47	9.98	14.9	20.8
		Output Torque Nm, Mechanical	780	1091	1878	2951	4445	6215
		Efficiency %	84.1	86.0	87.2	88.3	88.8	89.2
500	20.0	Actual Output Speed, rpm	19.1	19.1	19.1	19.0	19.0	19.0
		Input kW, Thermal	3.65	5.59	9.72	15.5	22.0	30.0
		Output Torque Nm, Thermal	1501	2358	4167	6775	9671	13247
		Input kW, Mechanical	2.10	2.58	4.36	7.54	11.3	15.9
		Output Torque Nm, Mechanical	865	1086	1868	3298	4973	7002
		Efficiency %	82.5	84.5	85.8	87.0	87.5	87.9
250	10.0	Actual Output Speed, rpm	9.6	9.6	9.6	9.5	9.5	9.5
		Input kW, Thermal	3.07	4.71	8.11	12.9	18.2	24.6
		Output Torque Nm, Thermal	2457	3876	6788	10995	15603	21212
		Input kW, Mechanical	1.29	1.31	2.21	3.85	6.25	9.64
		Output Torque Nm, Mechanical	1034	1076	1851	3280	5360	8308
		Efficiency %	79.8	82.3	83.6	84.8	85.3	85.8

For details of unit designation code see page 13.



Units to ATEX approval must be selected with a minimum service factor of 1.25.

RENOLD PM Series - PH Type - Selection Data

Nominal ratio: 32/1

Input rpm	Nominal Output rpm	Product Code Actual Ratio Overall Ratio	PH3REDXXXSD***	PH4REDXXXSD***	PH5REDXXXSD***	PH6REDXXXSD***	PH7REDXXXSD***	PH8REDXXXSD***
			Helical 32/70 Worm 2/31	Helical 32/70 Worm 2/31	Helical 32/70 Worm 2/31	Helical 25/56 Worm 3/44	Helical 25/56 Worm 3/44	Helical 25/56 Worm 3/44
			33.91	33.91	33.91	32.85	32.85	32.85
1800	56.3	Actual Output Speed, rpm	53.1	53.1	53.1	54.8	54.8	54.8
		Input kW, Thermal	5.06	7.75	13.7	22.2	32.1	44.2
		Output Torque Nm, Thermal	787	1230	2202	3493	5079	7023
		Input kW, Mechanical	4.12	5.90	10.4	15.2	22.6	31.4
		Output Torque Nm, Mechanical	641	936	1674	2384	3579	4991
		Efficiency %	86.5	88.2	89.3	90.3	90.8	91.2
1500	46.9	Actual Output Speed, rpm	44.2	44.2	44.2	45.7	45.7	45.7
		Input kW, Thermal	4.74	7.26	12.8	20.7	29.9	41.1
		Output Torque Nm, Thermal	877	1372	2452	3887	5639	7786
		Input kW, Mechanical	3.69	5.26	9.33	13.5	20.2	28.1
		Output Torque Nm, Mechanical	681	994	1786	2541	3810	5319
		Efficiency %	85.7	87.5	88.7	89.8	90.2	90.6
1200	37.5	Actual Output Speed, rpm	35.4	35.4	35.4	36.5	36.5	36.5
		Input kW, Thermal	4.39	6.73	11.8	19.1	27.4	37.7
		Output Torque Nm, Thermal	1006	1575	2807	4449	6417	8869
		Input kW, Mechanical	3.19	4.56	7.94	11.8	17.6	24.4
		Output Torque Nm, Mechanical	731	1065	1883	2752	4116	5750
		Efficiency %	84.8	86.7	88.0	89.1	89.6	90.0
1000	31.3	Actual Output Speed, rpm	29.5	29.5	29.5	30.4	30.4	30.4
		Input kW, Thermal	4.14	6.34	11.1	17.9	25.7	35.3
		Output Torque Nm, Thermal	1130	1771	3147	4970	7175	9899
		Input kW, Mechanical	2.84	3.92	6.65	10.4	15.6	21.7
		Output Torque Nm, Mechanical	774	1092	1879	2888	4343	6090
		Efficiency %	84.2	86.1	87.3	88.5	89.0	89.4
750	23.4	Actual Output Speed, rpm	22.1	22.1	22.1	22.8	22.8	22.8
		Input kW, Thermal	3.80	5.82	10.1	16.3	23.3	31.8
		Output Torque Nm, Thermal	1362	2139	3787	5973	8587	11772
		Input kW, Mechanical	2.34	2.96	5.02	8.54	12.7	17.8
		Output Torque Nm, Mechanical	837	1088	1872	3131	4690	6580
		Efficiency %	83.0	85.0	86.3	87.6	88.1	88.5
500	15.6	Actual Output Speed, rpm	14.7	14.7	14.7	15.2	15.2	15.2
		Input kW, Thermal	3.41	5.22	9.04	14.5	20.6	28.0
		Output Torque Nm, Thermal	1795	2825	4976	7853	11221	15322
		Input kW, Mechanical	1.77	2.00	3.39	6.04	9.68	13.5
		Output Torque Nm, Mechanical	928	1082	1862	3271	5271	7406
		Efficiency %	81.4	83.7	85.0	86.3	86.8	87.2
250	7.8	Actual Output Speed, rpm	7.4	7.4	7.4	7.6	7.6	7.6
		Input kW, Thermal	2.91	4.45	7.65	12.2	17.2	23.2
		Output Torque Nm, Thermal	2985	4715	8234	12897	18268	24756
		Input kW, Mechanical	1.06	1.01	1.72	3.07	4.98	7.68
		Output Torque Nm, Mechanical	1088	1073	1845	3246	5289	8191
		Efficiency %	78.9	81.4	82.8	84.2	84.6	85.0

For details of unit designation code see page 13.



IMPORTANT

Units to ATEX approval must be selected with a minimum service factor of 1.25.

RENOLD PM Series - PH Type - Selection Data

Nominal ratio: 40/1

Input rpm	Nominal Output rpm	Product Code Actual Ratio Overall Ratio	PH3REDXXXSE***	PH4REDXXXSE***	PH5REDXXXSE***	PH6REDXXXSE***	PH7REDXXXSE***	PH8REDXXXSE***
			Helical 29/73 Worm 2/31	Helical 29/73 Worm 2/31	Helical 44/58 Worm 1/30	Helical 27/76 Worm 3/44	Helical 27/76 Worm 3/44	Helical 27/76 Worm 3/44
			39.02	39.02	39.55	41.28	41.28	41.28
1800	45.0	Actual Output Speed, rpm	46.1	46.1	45.5	43.6	43.6	43.6
		Input kW, Thermal	4.81	7.37	9.27	20.8	29.9	41.2
		Output Torque Nm, Thermal	855	1338	1654	4090	5912	8182
		Input kW, Mechanical	3.78	5.39	9.15	13.6	20.3	28.2
		Output Torque Nm, Mechanical	672	980	1633	2681	4014	5596
		Efficiency %	85.9	87.7	85.0	89.8	90.3	90.7
1500	37.5	Actual Output Speed, rpm	38.4	38.4	37.9	36.3	36.3	36.3
		Input kW, Thermal	4.51	6.92	8.63	19.4	27.9	38.4
		Output Torque Nm, Thermal	956	1497	1829	4548	6576	9091
		Input kW, Mechanical	3.37	4.81	8.32	12.1	18.1	25.1
		Output Torque Nm, Mechanical	713	1040	1763	2841	4261	5954
		Efficiency %	85.2	87.0	84.2	89.2	89.7	90.1
1200	30.0	Actual Output Speed, rpm	30.8	30.8	30.3	29.1	29.1	29.1
		Input kW, Thermal	4.20	6.43	7.92	18.0	25.8	35.3
		Output Torque Nm, Thermal	1099	1723	2071	5233	7543	10366
		Input kW, Mechanical	2.92	4.08	7.18	10.4	15.7	21.8
		Output Torque Nm, Mechanical	764	1092	1877	3025	4577	6407
		Efficiency %	84.3	86.2	83.1	88.5	89.0	89.4
1000	25.0	Actual Output Speed, rpm	25.6	25.6	25.3	24.2	24.2	24.2
		Input kW, Thermal	3.97	6.08	7.40	16.9	24.2	33.1
		Output Torque Nm, Thermal	1237	1941	2296	5857	8434	11600
		Input kW, Mechanical	2.59	3.41	6.43	9.20	13.7	19.3
		Output Torque Nm, Mechanical	806	1090	1996	3189	4787	6760
		Efficiency %	83.6	85.6	82.2	87.9	88.4	88.9
750	18.8	Actual Output Speed, rpm	19.2	19.2	19.0	18.2	18.2	18.2
		Input kW, Thermal	3.65	5.59	6.69	15.5	22.0	30.0
		Output Torque Nm, Thermal	1497	2353	2719	7089	10120	13862
		Input kW, Mechanical	2.11	2.59	5.40	7.54	11.3	15.9
		Output Torque Nm, Mechanical	864	1086	2196	3451	5203	7327
		Efficiency %	82.5	84.5	80.7	87.0	87.5	87.9
500	12.5	Actual Output Speed, rpm	12.8	12.8	12.6	12.1	12.1	12.1
		Input kW, Thermal	3.29	5.04	5.87	13.8	19.6	26.6
		Output Torque Nm, Thermal	1983	3123	3493	9328	13324	18187
		Input kW, Mechanical	1.60	1.75	4.11	5.10	8.28	11.9
		Output Torque Nm, Mechanical	962	1080	2444	3448	5630	8149
		Efficiency %	80.9	83.2	78.6	85.7	86.2	86.7
250	6.3	Actual Output Speed, rpm	6.4	6.4	6.3	6.1	6.1	6.1
		Input kW, Thermal	2.83	4.33	4.87	11.7	16.5	22.2
		Output Torque Nm, Thermal	3323	5254	5532	15451	21893	29595
		Input kW, Mechanical	0.95	0.88	2.54	2.59	4.20	6.47
		Output Torque Nm, Mechanical	1120	1071	2879	3415	5575	8631
		Efficiency %	78.4	81.0	75.2	83.8	84.2	84.5

For details of unit designation code see page 13.



Units to ATEX approval must be selected with a minimum service factor of 1.25.

RENOLD PM Series - PH Type - Selection Data

Nominal ratio: 50/1

Input rpm	Nominal Output rpm	Product Code Actual Ratio Overall Ratio	PH3REDXXXSF***	PH4REDXXXSF***	PH5REDXXXSF***	PH6REDXXXSF***	PH7REDXXXSF***	PH8REDXXXSF***
			Helical 24/78 Worm 2/31	Helical 24/78 Worm 2/31	Helical 38/64 Worm 1/30	Helical 23/80 Worm 3/44	Helical 23/80 Worm 3/44	Helical 23/80 Worm 3/44
			50.38	50.38	50.53	51.01	51.01	51.01
1800	36.0	Actual Output Speed, rpm	35.7	35.7	35.6	35.3	35.3	35.3
		Input kW, Thermal	4.41	6.75	8.42	19.3	27.8	38.2
		Output Torque Nm, Thermal	1000	1566	1893	4659	6748	9313
		Input kW, Mechanical	3.21	4.59	8.01	12.0	18.0	24.9
		Output Torque Nm, Mechanical	729	1063	1800	2901	4364	6082
		Efficiency %	84.9	86.8	83.9	89.2	89.7	90.1
1500	30.0	Actual Output Speed, rpm	29.8	29.8	29.7	29.4	29.4	29.4
		Input kW, Thermal	4.16	6.37	7.85	18.1	26.0	35.7
		Output Torque Nm, Thermal	1122	1758	2096	5208	7523	10375
		Input kW, Mechanical	2.86	3.96	7.08	10.7	16.0	22.2
		Output Torque Nm, Mechanical	771	1092	1889	3080	4617	6458
		Efficiency %	84.2	86.1	83.0	88.6	89.1	89.5
1200	24.0	Actual Output Speed, rpm	23.8	23.8	23.7	23.5	23.5	23.5
		Input kW, Thermal	3.88	5.95	7.24	16.9	24.1	33.0
		Output Torque Nm, Thermal	1298	2037	2381	6031	8649	11896
		Input kW, Mechanical	2.46	3.18	6.21	9.15	13.6	19.1
		Output Torque Nm, Mechanical	822	1089	2042	3265	4893	6881
		Efficiency %	83.3	85.3	81.9	87.9	88.4	88.8
1000	20.0	Actual Output Speed, rpm	19.8	19.8	19.8	19.6	19.6	19.6
		Input kW, Thermal	3.69	5.65	6.79	15.9	22.7	31.0
		Output Torque Nm, Thermal	1464	2301	2650	6763	9710	13320
		Input kW, Mechanical	2.16	2.67	5.56	8.09	12.1	16.9
		Output Torque Nm, Mechanical	858	1086	2168	3441	5184	7247
		Efficiency %	82.6	84.6	80.9	87.3	87.8	88.2
750	15.0	Actual Output Speed, rpm	14.9	14.9	14.8	14.7	14.7	14.7
		Input kW, Thermal	3.42	5.23	6.17	14.6	20.8	28.3
		Output Torque Nm, Thermal	1784	2809	3158	8195	11742	16049
		Input kW, Mechanical	1.78	2.02	4.58	6.26	9.93	13.9
		Output Torque Nm, Mechanical	925	1082	2337	3515	5605	7904
		Efficiency %	81.5	83.7	79.4	86.4	86.9	87.3
500	10.0	Actual Output Speed, rpm	9.9	9.9	9.9	9.8	9.8	9.8
		Input kW, Thermal	3.10	4.75	5.47	13.2	18.6	25.2
		Output Torque Nm, Thermal	2386	3764	4089	10949	15517	21121
		Input kW, Mechanical	1.33	1.36	3.47	4.21	6.84	10.3
		Output Torque Nm, Mechanical	1025	1077	2592	3493	5705	8634
		Efficiency %	80.0	82.4	77.3	85.1	85.6	86.0
250	5.0	Actual Output Speed, rpm	5.0	5.0	4.9	4.9	4.9	4.9
		Input kW, Thermal	2.70	4.13	4.60	11.3	15.8	21.3
		Output Torque Nm, Thermal	4038	6390	6600	18310	25753	34883
		Input kW, Mechanical	0.79	0.69	2.06	2.14	3.47	5.35
		Output Torque Nm, Mechanical	1182	1068	2961	3469	5663	8767
		Efficiency %	77.6	80.3	74.1	83.2	83.7	84.1

For details of unit designation code see page 13.



Units to ATEX approval must be selected with a minimum service factor of 1.25.

RENOLD PM Series - PH Type - Selection Data

Nominal ratio: 63/1

Input rpm	Nominal Output rpm	Product Code Actual Ratio Overall Ratio	PH3REDXXXSG***	PH4REDXXXSG***	PH5REDXXXSG***	PH6REDXXXSG***	PH7REDXXXSG***	PH8REDXXXSG***
			Helical 20/82 Worm 2/31	Helical 32/70 Worm 1/30	Helical 32/70 Worm 1/30	Helical 21/82 Worm 3/44	Helical 21/82 Worm 3/44	Helical 21/82 Worm 3/44
			63.55	65.63	65.63	57.27	57.27	57.27
1800	28.6	Actual Output Speed, rpm	28.3	27.4	27.4	31.4	31.4	31.4
		Input kW, Thermal	4.09	4.50	7.62	18.2	26.2	35.9
		Output Torque Nm, Thermal	1159	1276	2192	4900	7093	9772
		Input kW, Mechanical	2.77	4.01	6.76	10.8	16.2	22.4
		Output Torque Nm, Mechanical	784	1136	1941	2909	4375	6104
		Efficiency %	84.0	81.4	82.6	88.6	89.1	89.6
1500	23.8	Actual Output Speed, rpm	23.6	22.9	22.9	26.2	26.2	26.2
		Input kW, Thermal	3.87	4.23	7.14	17.1	24.5	33.6
		Output Torque Nm, Thermal	1305	1422	2434	5493	7915	10903
		Input kW, Mechanical	2.44	3.57	6.07	9.47	14.2	19.8
		Output Torque Nm, Mechanical	824	1197	2068	3043	4601	6424
		Efficiency %	83.3	80.5	81.7	88.1	88.6	89.0
1200	19.0	Actual Output Speed, rpm	18.9	18.3	18.3	21.0	21.0	21.0
		Input kW, Thermal	3.64	3.93	6.61	16.0	22.8	31.1
		Output Torque Nm, Thermal	1515	1629	2778	6367	9125	12516
		Input kW, Mechanical	2.08	3.08	5.28	8.16	12.2	17.1
		Output Torque Nm, Mechanical	867	1277	2218	3248	4891	6870
		Efficiency %	82.4	79.3	80.5	87.3	87.8	88.3
1000	15.9	Actual Output Speed, rpm	15.7	15.2	15.2	17.5	17.5	17.5
		Input kW, Thermal	3.46	3.72	6.23	15.1	21.5	29.3
		Output Torque Nm, Thermal	1718	1829	3107	7170	10267	14055
		Input kW, Mechanical	1.84	2.74	4.66	7.03	10.8	15.0
		Output Torque Nm, Mechanical	910	1346	2321	3338	5161	7219
		Efficiency %	81.7	78.4	79.5	86.8	87.3	87.7
750	11.9	Actual Output Speed, rpm	11.8	11.4	11.4	13.1	13.1	13.1
		Input kW, Thermal	3.23	3.43	5.70	14.0	19.8	26.9
		Output Torque Nm, Thermal	2105	2205	3720	8772	12478	17030
		Input kW, Mechanical	1.50	2.19	3.85	5.32	8.65	12.3
		Output Torque Nm, Mechanical	983	1411	2507	3335	5449	7801
		Efficiency %	80.6	76.9	78.1	85.9	86.4	86.8
500	7.9	Actual Output Speed, rpm	7.9	7.6	7.6	8.7	8.7	8.7
		Input kW, Thermal	2.95	3.09	5.10	12.6	17.8	24.1
		Output Torque Nm, Thermal	2836	2904	4865	11665	16576	22547
		Input kW, Mechanical	1.12	1.49	2.87	3.58	5.80	8.94
		Output Torque Nm, Mechanical	1073	1406	2732	3310	5399	8363
		Efficiency %	79.1	75.0	76.1	84.6	85.1	85.5
250	4.0	Actual Output Speed, rpm	3.9	3.8	3.8	4.4	4.4	4.4
		Input kW, Thermal	2.60	2.66	4.35	10.9	15.3	20.6
		Output Torque Nm, Thermal	4855	4825	7981	19735	27833	37653
		Input kW, Mechanical	0.66	0.77	1.62	1.83	2.96	4.57
		Output Torque Nm, Mechanical	1232	1397	2954	3310	5383	8344
		Efficiency %	76.9	72.0	73.0	82.8	83.2	83.6

For details of unit designation code see page 13.



Units to ATEX approval must be selected with a minimum service factor of 1.25.

RENOLD PM Series - PH Type - Selection Data

Nominal ratio: 80/1

Input rpm	Nominal Output rpm	Product Code Actual Ratio Overall Ratio	PH3REDXXXSH***	PH4REDXXXSH***	PH5REDXXXSH***	PH6REDXXXSH***	PH7REDXXXSH***	PH8REDXXXSH***
			Helical 16/86 Worm 2/31	Helical 29/73 Worm 1/30	Helical 29/73 Worm 1/30	Helical 15/88 Worm 3/44	Helical 21/119 Worm 3/44	Helical 21/119 Worm 3/44
			83.31	75.52	75.52	86.04	83.11	83.11
1800	22.5	Actual Output Speed, rpm	21.6	23.8	23.8	20.9	21.7	21.7
		Input kW, Thermal	3.77	4.29	7.24	16.3	23.2	31.7
		Output Torque Nm, Thermal	1384	1387	2377	6511	9003	12370
		Input kW, Mechanical	2.30	3.67	6.22	8.49	12.7	17.7
		Output Torque Nm, Mechanical	842	1184	2040	3393	4938	6897
		Efficiency %	82.9	80.7	81.9	87.5	88.0	88.5
1500	18.8	Actual Output Speed, rpm	18.0	19.9	19.9	17.4	18.0	18.0
		Input kW, Thermal	3.59	4.04	6.80	15.4	21.9	29.9
		Output Torque Nm, Thermal	1566	1548	2644	7340	10141	13908
		Input kW, Mechanical	2.01	3.25	5.57	7.44	11.2	15.7
		Output Torque Nm, Mechanical	875	1248	2166	3548	5191	7282
		Efficiency %	82.2	79.7	80.9	87.0	87.5	87.9
1200	15.0	Actual Output Speed, rpm	14.4	15.9	15.9	13.9	14.4	14.4
		Input kW, Thermal	3.39	3.77	6.31	14.4	20.5	27.9
		Output Torque Nm, Thermal	1830	1779	3025	8502	11758	16094
		Input kW, Mechanical	1.73	2.82	4.80	5.99	9.61	13.4
		Output Torque Nm, Mechanical	934	1331	2298	3536	5509	7749
		Efficiency %	81.3	78.6	79.8	86.2	86.7	87.2
1000	12.5	Actual Output Speed, rpm	12.0	13.2	13.2	11.6	12.0	12.0
		Input kW, Thermal	3.24	3.57	5.96	13.7	19.5	26.4
		Output Torque Nm, Thermal	2081	2002	3392	9650	13345	18150
		Input kW, Mechanical	1.53	2.49	4.24	4.99	8.10	11.7
		Output Torque Nm, Mechanical	979	1397	2414	3515	5543	8055
		Efficiency %	80.7	77.7	78.8	85.7	86.2	86.6
750	9.4	Actual Output Speed, rpm	9.0	9.9	9.9	8.7	9.0	9.0
		Input kW, Thermal	3.04	3.30	5.48	12.8	18.1	24.4
		Output Torque Nm, Thermal	2560	2423	4080	11897	16345	22136
		Input kW, Mechanical	1.24	1.92	3.48	3.77	6.12	9.42
		Output Torque Nm, Mechanical	1046	1409	2590	3502	5527	8549
		Efficiency %	79.6	76.2	77.4	84.8	85.3	85.7
500	6.3	Actual Output Speed, rpm	6.0	6.6	6.6	5.8	6.0	6.0
		Input kW, Thermal	2.80	2.99	4.93	11.7	16.4	22.1
		Output Torque Nm, Thermal	3487	3207	5357	16083	21880	29658
		Input kW, Mechanical	0.91	1.31	2.62	2.54	4.11	6.34
		Output Torque Nm, Mechanical	1136	1404	2846	3485	5484	8512
		Efficiency %	78.2	74.3	75.4	83.7	84.1	84.5
250	3.1	Actual Output Speed, rpm	3.0	3.3	3.3	2.9	3.0	3.0
		Input kW, Thermal	2.49	2.59	4.23	10.3	14.4	19.2
		Output Torque Nm, Thermal	5990	5371	8863	27715	37608	50325
		Input kW, Mechanical	0.54	0.68	1.41	1.28	2.08	3.21
		Output Torque Nm, Mechanical	1286	1396	2951	3451	5434	8418
		Efficiency %	76.1	71.4	72.4	81.9	82.3	82.6

For details of unit designation code see page 13.



Units to ATEX approval must be selected with a minimum service factor of 1.25.

RENOLD PM Series - PH Type - Selection Data

Nominal ratio: 100/1

Input rpm	Nominal Output rpm	Product Code Actual Ratio Overall Ratio	PH3REDXXSJ***	PH4REDXXSJ***	PH5REDXXSJ***	PH6REDXXSJ***	PH7REDXXSJ***	PH8REDXXSJ***
			Helical 13/89 Worm 2/31	Helical 24/78 Worm 1/30	Helical 24/78 Worm 1/30	Helical 13/90 Worm 3/44	Helical 13/90 Worm 3/44	Helical 13/90 Worm 3/44
			106.12	97.50	97.50	101.54	101.54	101.54
1800	18.0	Actual Output Speed, rpm	17.0	18.5	18.5	17.7	17.7	17.7
		Input kW, Thermal	3.53	3.94	6.63	15.4	22.0	29.9
		Output Torque Nm, Thermal	1631	1620	2763	7219	10372	14160
		Input kW, Mechanical	1.93	3.10	5.31	7.47	11.2	15.8
		Output Torque Nm, Mechanical	889	1274	2212	3504	5285	7462
		Efficiency %	82.0	79.4	80.5	87.0	87.5	87.9
1500	15.0	Actual Output Speed, rpm	14.1	15.4	15.4	14.8	14.8	14.8
		Input kW, Thermal	3.37	3.73	6.25	14.6	20.8	28.2
		Output Torque Nm, Thermal	1852	1816	3086	8157	11687	15917
		Input kW, Mechanical	1.71	2.76	4.69	6.23	9.90	13.8
		Output Torque Nm, Mechanical	939	1342	2315	3482	5562	7810
		Efficiency %	81.3	78.4	79.6	86.4	86.9	87.3
1200	12.0	Actual Output Speed, rpm	11.3	12.3	12.3	11.8	11.8	11.8
		Input kW, Thermal	3.19	3.50	5.83	13.8	19.5	26.5
		Output Torque Nm, Thermal	2174	2101	3553	9560	13587	18549
		Input kW, Mechanical	1.46	2.35	4.04	5.02	8.15	11.8
		Output Torque Nm, Mechanical	995	1412	2461	3477	5679	8271
		Efficiency %	80.4	77.3	78.4	85.7	86.2	86.6
1000	10.0	Actual Output Speed, rpm	9.4	10.3	10.3	9.8	9.8	9.8
		Input kW, Thermal	3.07	3.33	5.53	13.2	18.6	25.2
		Output Torque Nm, Thermal	2482	2369	3992	10897	15444	21022
		Input kW, Mechanical	1.28	1.98	3.57	4.21	6.84	10.3
		Output Torque Nm, Mechanical	1037	1410	2571	3477	5678	8594
		Efficiency %	79.8	76.4	77.5	85.1	85.6	86.0
750	7.5	Actual Output Speed, rpm	7.1	7.7	7.7	7.4	7.4	7.4
		Input kW, Thermal	2.89	3.10	5.12	12.3	17.3	23.4
		Output Torque Nm, Thermal	3067	2886	4836	13413	18954	25787
		Input kW, Mechanical	1.03	1.52	2.89	3.18	5.16	7.96
		Output Torque Nm, Mechanical	1095	1406	2727	3469	5655	8771
		Efficiency %	78.8	75.0	76.1	84.3	84.7	85.2
500	5.0	Actual Output Speed, rpm	4.7	5.1	5.1	4.9	4.9	4.9
		Input kW, Thermal	2.68	2.83	4.64	11.3	15.8	21.3
		Output Torque Nm, Thermal	4210	3858	6415	18223	25632	34719
		Input kW, Mechanical	0.76	1.03	2.14	2.14	3.47	5.35
		Output Torque Nm, Mechanical	1194	1401	2962	3453	5637	8725
		Efficiency %	77.5	73.3	74.3	83.2	83.7	84.1
250	2.5	Actual Output Speed, rpm	2.4	2.6	2.6	2.5	2.5	2.5
		Input kW, Thermal	2.41	2.48	4.03	10.0	13.9	18.6
		Output Torque Nm, Thermal	7288	6523	10723	31563	44086	59278
		Input kW, Mechanical	0.43	0.53	1.11	1.08	1.76	2.71
		Output Torque Nm, Mechanical	1299	1393	2945	3411	5574	8627
		Efficiency %	75.5	70.5	71.4	81.4	81.8	82.2

For details of unit designation code see page 13.



Units to ATEX approval must be selected with a minimum service factor of 1.25.

RENOLD PM Series - PH Type - Selection Data

Nominal ratio: 125/1

Input rpm	Nominal Output rpm	Product Code Actual Ratio Overall Ratio	PH3REDXXXSK***	PH4REDXXXSK***	PH5REDXXXSK***	PH6REDXXXSK***	PH7REDXXXSK***	PH8REDXXXSK***
			Helical 11/91 Worm 2/31	Helical 20/82 Worm 1/30	Helical 20/82 Worm 1/30	Helical 21/82 Worm 1/30	Helical 13/107 Worm 3/44	Helical 13/107 Worm 3/44
			128.23	123.00	123.00	117.14	120.72	120.72
1800	14.4	Actual Output Speed, rpm	14.0	14.6	14.6	15.4	14.9	14.9
		Input kW, Thermal	3.37	3.67	6.15	9.46	20.6	28.0
		Output Torque Nm, Thermal	1858	1876	3185	4726	11455	15640
		Input kW, Mechanical	1.71	2.67	4.53	6.65	9.74	13.6
		Output Torque Nm, Mechanical	940	1361	2347	3320	5414	7616
		Efficiency %	81.3	78.2	79.3	80.4	86.8	87.2
1500	12.0	Actual Output Speed, rpm	11.7	12.2	12.2	12.8	12.4	12.4
		Input kW, Thermal	3.22	3.49	5.81	8.91	19.6	26.6
		Output Torque Nm, Thermal	2122	2112	3571	5276	12989	17729
		Input kW, Mechanical	1.49	2.33	4.02	5.84	8.28	11.9
		Output Torque Nm, Mechanical	986	1412	2467	3457	5488	7943
		Efficiency %	80.6	77.2	78.4	79.4	86.2	86.7
1200	9.6	Actual Output Speed, rpm	9.4	9.8	9.8	10.2	9.9	9.9
		Input kW, Thermal	3.06	3.29	5.45	8.32	18.5	25.0
		Output Torque Nm, Thermal	2495	2450	4125	6073	15202	20662
		Input kW, Mechanical	1.27	1.89	3.44	5.03	6.66	10.1
		Output Torque Nm, Mechanical	1039	1409	2600	3672	5469	8347
		Efficiency %	79.8	76.1	77.3	78.3	85.5	86.0
1000	8.0	Actual Output Speed, rpm	7.8	8.1	8.1	8.5	8.3	8.3
		Input kW, Thermal	2.95	3.14	5.19	7.90	17.7	23.8
		Output Torque Nm, Thermal	2854	2778	4660	6841	17352	23441
		Input kW, Mechanical	1.11	1.60	3.01	4.41	5.58	8.59
		Output Torque Nm, Mechanical	1075	1407	2697	3822	5466	8455
		Efficiency %	79.1	75.3	76.4	77.4	85.0	85.4
750	6.0	Actual Output Speed, rpm	5.8	6.1	6.1	6.4	6.2	6.2
		Input kW, Thermal	2.79	2.93	4.83	7.32	16.5	22.2
		Output Torque Nm, Thermal	3546	3405	5679	8301	21342	28849
		Input kW, Mechanical	0.90	1.21	2.47	3.62	4.20	6.47
		Output Torque Nm, Mechanical	1142	1403	2903	4100	5434	8413
		Efficiency %	78.2	74.0	75.0	76.0	84.2	84.5
500	4.0	Actual Output Speed, rpm	3.9	4.1	4.1	4.3	4.1	4.1
		Input kW, Thermal	2.59	2.70	4.41	6.64	15.2	20.4
		Output Torque Nm, Thermal	4919	4585	7593	11015	29109	39253
		Input kW, Mechanical	0.65	0.82	1.72	2.72	2.83	4.35
		Output Torque Nm, Mechanical	1236	1398	2956	4507	5416	8376
		Efficiency %	76.8	72.3	73.3	74.2	83.1	83.5
250	2.0	Actual Output Speed, rpm	1.9	2.0	2.0	2.1	2.1	2.1
		Input kW, Thermal	2.34	2.39	3.88	5.79	13.5	18.0
		Output Torque Nm, Thermal	8679	7841	12844	18466	50597	67709
		Input kW, Mechanical	0.35	0.43	0.89	1.60	1.43	2.20
		Output Torque Nm, Mechanical	1297	1390	2939	5090	5375	8282
		Efficiency %	74.9	69.6	70.5	71.3	81.3	81.6

For details of unit designation code see page 13.



Units to ATEX approval must be selected with a minimum service factor of 1.25.

RENOLD PM Series - PH Type - Selection Data

Nominal ratio: 160/1

Input rpm	Nominal Output rpm	Product Code Actual Ratio Overall Ratio	PH3REDXXXSL***	PH4REDXXXSL***	PH5REDXXXSL***	PH6REDXXXSL***	PH7REDXXXSL***	PH8REDXXXSL***
			Helical 16/86 Worm 1/30	Helical 16/86 Worm 1/30	Helical 16/86 Worm 1/30	Helical 15/88 Worm 1/30	Helical 21/82 Worm 1/40	Helical 21/82 Worm 1/40
			161.25	161.25	161.25	176.00	156.19	156.19
1800	11.3	Actual Output Speed, rpm	11.2	11.2	11.2	10.2	11.5	11.5
		Input kW, Thermal	2.07	3.40	5.66	8.47	11.1	15.4
		Output Torque Nm, Thermal	1278	2239	3780	6217	7166	10056
		Input kW, Mechanical	1.41	2.15	3.78	5.23	7.41	9.99
		Output Torque Nm, Mechanical	874	1411	2522	3840	4786	6523
		Efficiency %	72.2	76.8	77.9	78.6	77.9	78.8
1500	9.4	Actual Output Speed, rpm	9.3	9.3	9.3	8.5	9.6	9.6
		Input kW, Thermal	1.97	3.24	5.38	8.03	10.5	14.4
		Output Torque Nm, Thermal	1442	2533	4261	6992	8021	11128
		Input kW, Mechanical	1.24	1.81	3.32	4.61	6.49	8.78
		Output Torque Nm, Mechanical	908	1408	2627	4010	4961	6782
		Efficiency %	71.2	75.9	77.0	77.7	76.8	77.7
1200	7.5	Actual Output Speed, rpm	7.4	7.4	7.4	6.8	7.7	7.7
		Input kW, Thermal	1.86	3.07	5.07	7.55	9.79	13.5
		Output Torque Nm, Thermal	1678	2958	4954	8103	9191	12841
		Input kW, Mechanical	1.07	1.46	2.82	3.94	5.60	7.50
		Output Torque Nm, Mechanical	960	1406	2753	4227	5253	7138
		Efficiency %	70.0	74.8	75.9	76.6	75.5	76.5
1000	6.3	Actual Output Speed, rpm	6.2	6.2	6.2	5.7	6.4	6.4
		Input kW, Thermal	1.79	2.95	4.85	7.20	9.29	12.7
		Output Torque Nm, Thermal	1904	3365	5614	9165	10329	14308
		Input kW, Mechanical	0.94	1.23	2.50	3.46	4.99	6.72
		Output Torque Nm, Mechanical	1001	1403	2893	4410	5548	7567
		Efficiency %	69.0	74.1	75.1	75.7	74.5	75.5
750	4.7	Actual Output Speed, rpm	4.7	4.7	4.7	4.3	4.8	4.8
		Input kW, Thermal	1.68	2.77	4.54	6.72	8.60	11.8
		Output Torque Nm, Thermal	2332	4138	6870	11196	12495	17354
		Input kW, Mechanical	0.77	0.94	1.96	2.83	4.08	5.52
		Output Torque Nm, Mechanical	1062	1400	2959	4712	5929	8125
		Efficiency %	67.6	72.8	73.9	74.3	73.1	74.0
500	3.1	Actual Output Speed, rpm	3.1	3.1	3.1	2.8	3.2	3.2
		Input kW, Thermal	1.56	2.57	4.18	6.16	7.79	10.6
		Output Torque Nm, Thermal	3160	5635	9289	15026	16495	22726
		Input kW, Mechanical	0.56	0.64	1.32	2.06	3.04	4.10
		Output Torque Nm, Mechanical	1137	1395	2949	5026	6437	8792
		Efficiency %	65.7	71.2	72.1	72.6	71.0	71.9
250	1.6	Actual Output Speed, rpm	1.6	1.6	1.6	1.4	1.6	1.6
		Input kW, Thermal	1.40	2.30	3.72	5.45	6.79	9.19
		Output Torque Nm, Thermal	5384	9672	15787	25608	27471	37670
		Input kW, Mechanical	0.34	0.33	0.69	1.13	1.68	2.43
		Output Torque Nm, Mechanical	1289	1387	2933	5315	6783	9977
		Efficiency %	63.1	68.7	69.5	69.9	67.8	68.7

For details of unit designation code see page 13.



Units to ATEX approval must be selected with a minimum service factor of 1.25.

RENOLD PM Series - PH Type - Selection Data

Nominal ratio: 200/1

Input rpm	Nominal Output rpm	Product Code Actual Ratio Overall Ratio	PH3REDXXXSM***	PH4REDXXXSM***	PH5REDXXXSM***	PH6REDXXXSM***	PH7REDXXXSM***	PH8REDXXXSM***
			Helical 13/89 Worm 1/30	Helical 13/89 Worm 1/30	Helical 13/89 Worm 1/30	Helical 13/90 Worm 1/30	Helical 17/86 Worm 1/40	Helical 17/86 Worm 1/40
			205.38	205.38	205.38	207.69	202.35	202.35
1800	9.0	Actual Output Speed, rpm	8.8	8.8	8.8	8.7	8.9	8.9
		Input kW, Thermal	1.94	3.20	5.29	8.04	10.5	14.4
		Output Torque Nm, Thermal	1500	2638	4431	6885	8659	12013
		Input kW, Mechanical	1.19	1.71	3.18	4.62	6.45	8.73
		Output Torque Nm, Mechanical	918	1408	2659	3952	5323	7280
		Efficiency %	70.9	75.6	76.7	77.7	76.8	77.7
1500	7.5	Actual Output Speed, rpm	7.3	7.3	7.3	7.2	7.4	7.4
		Input kW, Thermal	1.86	3.06	5.05	7.64	9.89	13.6
		Output Torque Nm, Thermal	1700	2996	5015	7760	9649	13442
		Input kW, Mechanical	1.05	1.43	2.79	4.05	5.71	7.65
		Output Torque Nm, Mechanical	964	1405	2769	4114	5567	7557
		Efficiency %	69.9	74.7	75.8	76.8	75.7	76.7
1200	6.0	Actual Output Speed, rpm	5.8	5.8	5.8	5.8	5.9	5.9
		Input kW, Thermal	1.76	2.91	4.78	7.21	9.27	12.7
		Output Torque Nm, Thermal	1988	3515	5860	9025	11128	15427
		Input kW, Mechanical	0.90	1.16	2.39	3.47	4.96	6.68
		Output Torque Nm, Mechanical	1014	1403	2934	4349	5953	8110
		Efficiency %	68.7	73.8	74.8	75.7	74.5	75.4
1000	5.0	Actual Output Speed, rpm	4.9	4.9	4.9	4.8	4.9	4.9
		Input kW, Thermal	1.70	2.80	4.58	6.90	8.82	12.1
		Output Torque Nm, Thermal	2263	4012	6666	10242	12536	17407
		Input kW, Mechanical	0.79	0.98	2.04	3.07	4.37	5.91
		Output Torque Nm, Mechanical	1054	1400	2961	4558	6216	8500
		Efficiency %	67.8	73.0	74.1	74.8	73.6	74.4
750	3.8	Actual Output Speed, rpm	3.7	3.7	3.7	3.6	3.7	3.7
		Input kW, Thermal	1.61	2.64	4.32	6.47	8.19	11.2
		Output Torque Nm, Thermal	2786	4957	8194	12585	15208	21054
		Input kW, Mechanical	0.64	0.75	1.56	2.47	3.56	4.79
		Output Torque Nm, Mechanical	1101	1397	2953	4813	6602	8999
		Efficiency %	66.5	71.8	72.8	73.6	72.1	73.0
500	2.5	Actual Output Speed, rpm	2.4	2.4	2.4	2.4	2.5	2.5
		Input kW, Thermal	1.49	2.46	4.00	5.96	7.47	10.1
		Output Torque Nm, Thermal	3804	6802	11172	16992	20206	27668
		Input kW, Mechanical	0.47	0.51	1.05	1.81	2.63	3.56
		Output Torque Nm, Mechanical	1197	1392	2943	5154	7103	9739
		Efficiency %	64.7	70.3	71.1	71.9	70.0	70.9
250	1.3	Actual Output Speed, rpm	1.2	1.2	1.2	1.2	1.2	1.2
		Input kW, Thermal	1.35	2.23	3.59	5.31	6.57	8.87
		Output Torque Nm, Thermal	6534	11767	19146	29193	34035	46493
		Input kW, Mechanical	0.28	0.26	0.55	0.96	1.40	2.05
		Output Torque Nm, Mechanical	1339	1384	2928	5269	7273	10747
		Efficiency %	62.3	68.0	68.7	69.3	67.0	67.8

For details of unit designation code see page 13.



Units to ATEX approval must be selected with a minimum service factor of 1.25.

RENOLD PM Series - PH Type - Selection Data

Nominal ratio: 250/1

Input rpm	Nominal Output rpm	Product Code Actual Ratio Overall Ratio	PH3REDXXXSN***	PH4REDXXXSN***	PH5REDXXXSN***	PH6REDXXXSN***	PH7REDXXXSN***	PH8REDXXXSN***
			Helical 11/91 Worm 1/30	Helical 11/91 Worm 1/30	Helical 11/91 Worm 1/30	Helical 13/107 Worm 1/30	Helical 13/90 Worm 1/40	Helical 13/90 Worm 1/40
			248.18	248.18	248.18	246.92	276.92	276.92
1800	7.2	Actual Output Speed, rpm	7.3	7.3	7.3	7.3	6.5	6.5
		Input kW, Thermal	1.85	3.05	5.04	7.59	9.45	13.0
		Output Torque Nm, Thermal	1705	3006	5031	7619	10404	14483
		Input kW, Mechanical	1.05	1.43	2.78	3.99	5.19	6.99
		Output Torque Nm, Mechanical	966	1405	2773	4005	5716	7787
		Efficiency %	69.9	74.7	75.8	76.6	74.9	75.8
1500	6.0	Actual Output Speed, rpm	6.0	6.0	6.0	6.1	5.4	5.4
		Input kW, Thermal	1.78	2.93	4.82	7.24	8.98	12.3
		Output Torque Nm, Thermal	1941	3431	5722	8631	11692	16229
		Input kW, Mechanical	0.92	1.20	2.45	3.51	4.59	6.19
		Output Torque Nm, Mechanical	1006	1403	2910	4190	5970	8169
		Efficiency %	68.9	74.0	74.9	75.8	73.9	74.8
1200	4.8	Actual Output Speed, rpm	4.8	4.8	4.8	4.9	4.3	4.3
		Input kW, Thermal	1.70	2.79	4.58	6.86	8.47	11.6
		Output Torque Nm, Thermal	2274	4032	6698	10075	13563	18828
		Input kW, Mechanical	0.79	0.97	2.03	3.01	3.90	5.28
		Output Torque Nm, Mechanical	1055	1400	2960	4420	6243	8574
		Efficiency %	67.8	73.0	74.0	74.7	72.7	73.7
1000	4.0	Actual Output Speed, rpm	4.0	4.0	4.0	4.0	3.6	3.6
		Input kW, Thermal	1.64	2.69	4.40	6.58	8.10	11.0
		Output Torque Nm, Thermal	2596	4613	7639	11474	15374	21137
		Input kW, Mechanical	0.69	0.82	1.71	2.63	3.44	4.64
		Output Torque Nm, Mechanical	1087	1398	2956	4579	6537	8908
		Efficiency %	66.9	72.2	73.2	74.0	71.8	72.7
750	3.0	Actual Output Speed, rpm	3.0	3.0	3.0	3.0	2.7	2.7
		Input kW, Thermal	1.55	2.56	4.16	6.19	7.59	10.3
		Output Torque Nm, Thermal	3213	5730	9444	14141	18837	25886
		Input kW, Mechanical	0.55	0.62	1.30	2.10	2.78	3.76
		Output Torque Nm, Mechanical	1142	1395	2949	4799	6893	9443
		Efficiency %	65.6	71.1	72.0	72.7	70.4	71.3
500	2.0	Actual Output Speed, rpm	2.0	2.0	2.0	2.0	1.8	1.8
		Input kW, Thermal	1.45	2.39	3.86	5.74	6.99	9.47
		Output Torque Nm, Thermal	4433	7945	13012	19241	25326	34758
		Input kW, Mechanical	0.41	0.42	0.87	1.53	1.96	2.76
		Output Torque Nm, Mechanical	1238	1390	2939	5112	7099	10120
		Efficiency %	64.0	69.6	70.4	71.1	68.5	69.4
250	1.0	Actual Output Speed, rpm	1.0	1.0	1.0	1.0	0.9	0.9
		Input kW, Thermal	1.32	2.17	3.49	5.15	6.22	8.39
		Output Torque Nm, Thermal	7765	14009	22736	33324	43249	59041
		Input kW, Mechanical	0.23	0.22	0.45	0.78	1.01	1.48
		Output Torque Nm, Mechanical	1377	1382	2923	5072	7023	10448
		Efficiency %	61.6	67.3	68.0	68.6	65.7	66.5

For details of unit designation code see page 13.



Units to ATEX approval must be selected with a minimum service factor of 1.25.

RENOLD PM Series - PH Type - Selection Data

Nominal ratio: 320/1

Input rpm	Nominal Output rpm	Product Code Actual Ratio Overall Ratio	PH7REDXXXSP***	PH8REDXXXSP***
			Helical 13/107 Worm 1/40	Helical 13/107 Worm 1/40
			329.23	329.23
1800	5.6	Actual Output Speed, rpm	5.47	5.47
		Input kW, Thermal	8.92	12.2
		Output Torque Nm, Thermal	11491	15906
		Input kW, Mechanical	4.51	6.09
		Output Torque Nm, Mechanical	5816	7940
		Efficiency %	73.8	74.6
1500	4.7	Actual Output Speed, rpm	4.56	4.56
		Input kW, Thermal	8.50	11.6
		Output Torque Nm, Thermal	12963	17932
		Input kW, Mechanical	3.95	5.34
		Output Torque Nm, Mechanical	6023	8259
		Efficiency %	72.8	73.8
1200	3.8	Actual Output Speed, rpm	3.64	3.64
		Input kW, Thermal	8.05	11.0
		Output Torque Nm, Thermal	15117	20913
		Input kW, Mechanical	3.37	4.55
		Output Torque Nm, Mechanical	6335	8641
		Efficiency %	71.7	72.6
1000	3.1	Actual Output Speed, rpm	3.04	3.04
		Input kW, Thermal	7.72	10.5
		Output Torque Nm, Thermal	17180	23661
		Input kW, Mechanical	2.95	3.98
		Output Torque Nm, Mechanical	6563	8967
		Efficiency %	70.8	71.7
750	2.3	Actual Output Speed, rpm	2.28	2.28
		Input kW, Thermal	7.26	9.86
		Output Torque Nm, Thermal	21120	29052
		Input kW, Mechanical	2.35	3.20
		Output Torque Nm, Mechanical	6846	9434
		Efficiency %	69.4	70.3
500	1.6	Actual Output Speed, rpm	1.52	1.52
		Input kW, Thermal	6.73	9.10
		Output Torque Nm, Thermal	28614	39143
		Input kW, Mechanical	1.61	2.34
		Output Torque Nm, Mechanical	6828	10079
		Efficiency %	67.6	68.4
250	0.78	Actual Output Speed, rpm	0.76	0.76
		Input kW, Thermal	6.04	8.13
		Output Torque Nm, Thermal	49330	67209
		Input kW, Mechanical	0.83	1.21
		Output Torque Nm, Mechanical	6781	10019
		Efficiency %	64.9	65.7

For details of unit designation code see page 13.



Units to ATEX approval must be selected with a minimum service factor of 1.25.

RENOLD PM Series - PH Type - Speed Reducer Dimensions

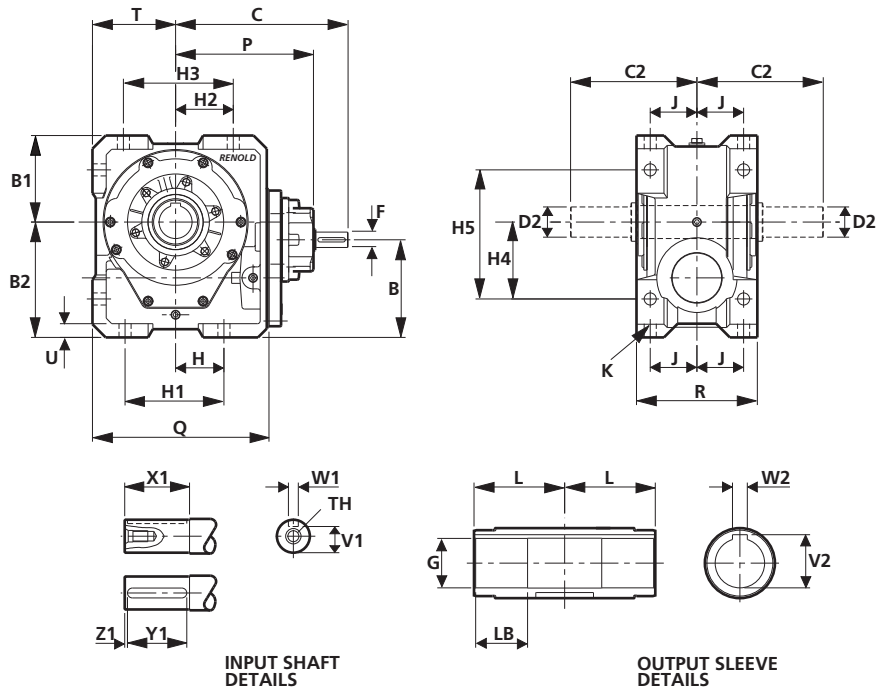

PM Series - PH Reduction Gear

UNIT REF	B	B1	B2	C	H	H1	H2	H3	H4	H5
PH35	162.0	140.0	180	288	60	135	85	160	120	205
PH40	179.3	157.5	210	314	88	180	105	200	140	235
PH50	183.9	195.0	240	334	88	180	125	230	160	280
PH60	239.6	225.0	280	442	120	235	145	270	190	340
PH70	269.2	255.5	335	457	140	290	160	310	240	412
PH80	278.8	280.0	370	481	140	310	170	340	256	460

UNIT REF	J	K	P	Q	R	T	U
PH35	75	17.0	225	274	186	130	25
PH40	85	21.5	251	321	220	151	25
PH50	100	21.5	271	365	250	175	30
PH60	125	25.5	329	418	305	200	35
PH70	150	25.5	344	458	360	225	35
PH80	150	25.5	368	503	360	246	35

Input Housing - Reduction

UNIT REF	F	V1	W1	X1	Y1	Z1	TH
PH35							
PH40	28j6	24.0	8P9	60	50	5	M10x22
PH50							
PH60							
PH70	42k6	37.0	12P9	110	110	5	M16x36
PH80							

Plug-in Output Shaft

UNIT REF	C2	D2
PH35	220	45k6
PH40	230	55m6
PH50	280	65m6
PH60	305	75m6
PH70	355	85m6
PH80	355	95m6

Output Sleeve

UNIT REF	G	L	LB	V2	W2
PH35	50F7	103	55	53.8	14Js9
PH40	60F7	110	65	64.4	18Js9
PH50	70F7	130	70	74.9	20Js9
PH60	90F7	155	90	95.4	25Js9
PH70	100F7	174	115	106.4	28Js9
PH80	100F7	174	115	106.4	28Js9

RENOLD PM Series - PH Type - Speed Reducer Dimensions

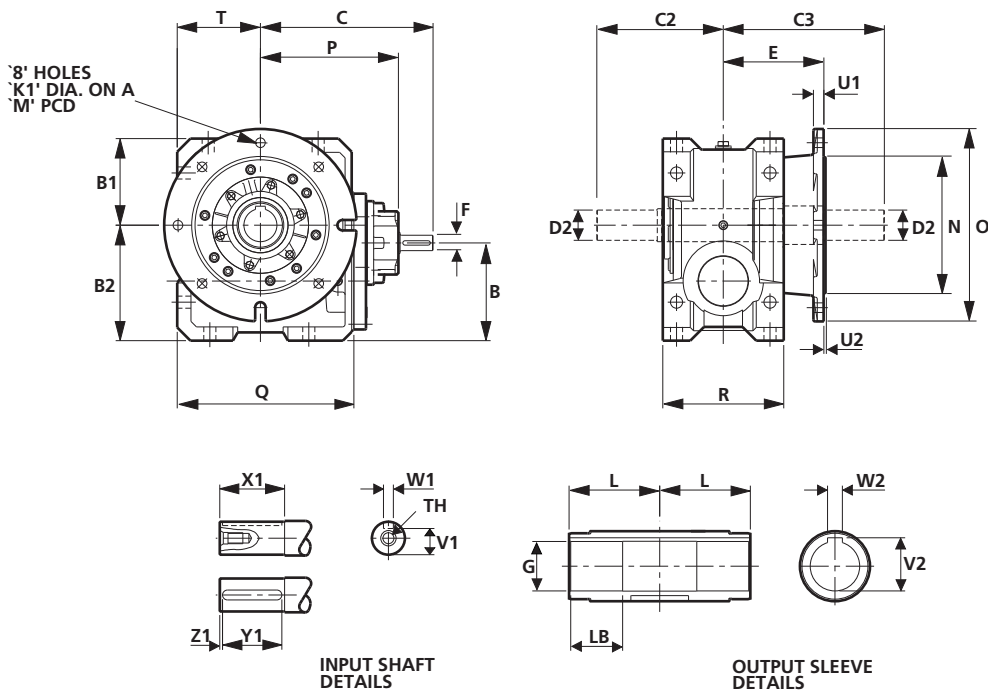

PM Series - PH Reduction Gear - (Horizontal Flange Mounted)

UNIT REF	B	B1	B2	C	E	K1	M	N	O
PH35	162.0	140.0	180	288	154	13.5	265	230h8	300
PH40	179.3	157.5	210	314	183	17.5	300	250h8	350
PH50	183.9	195.0	240	334	197	17.5	350	300h8	400
PH60	239.6	225.0	280	442	215	17.5	400	350h8	450
PH70	269.2	255.5	335	457	248	17.5	500	450h8	550
PH80	278.8	280.0	370	481	248	17.5	500	450h8	550

UNIT REF	P	Q	R	T	U1	U2
PH35	225	274	186	130	13	4
PH40	251	321	220	151	19	5
PH50	271	365	250	175	19	5
PH60	329	418	305	200	19	5
PH70	344	458	360	225	24	5
PH80	368	503	360	246	24	5

Input Housing - Reduction

UNIT REF	F	V1	W1	X1	Y1	Z1	TH
PH35							
PH40	28j6	24.0	8P9	60	50	5	M10x22
PH50							
PH60							
PH70	42k6	37.0	12P9	110	110	5	M16x36
PH80							

Output Sleeve

UNIT REF	G	L	LB	V2	W2
PH35	50F7	103	55	53.8	14Js9
PH40	60F7	110	65	64.4	18Js9
PH50	70F7	130	70	74.9	20Js9
PH60	90F7	155	90	95.4	25Js9
PH70	100F7	174	115	106.4	28Js9
PH80	100F7	174	115	106.4	28Js9

Plug-in Output Shaft

UNIT REF	C2	C3	D2
PH35	220	264	45k6
PH40	230	293	55m6
PH50	280	337	65m6
PH60	305	355	75m6
PH70	355	418	85m6
PH80	355	418	95m6

RENOLD PM Series - PH Type - Speed Reducer Dimensions

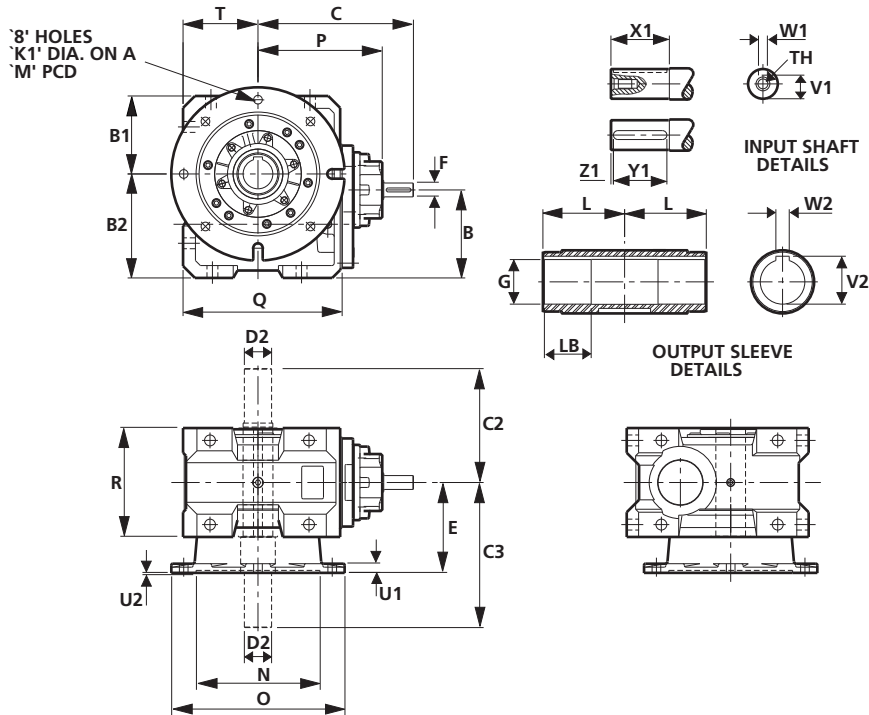

PM Series - PH Reduction Gear - (Vertical Skirt)

UNIT REF	B	B1	B2	C	E	K1	M	N	O
PH35	162.0	140.0	180	288	154	13.5	265	230H8	300
PH40	179.3	157.5	210	314	183	17.5	300	250H8	350
PH50	183.9	195.0	240	334	197	17.5	350	300H8	400
PH60	239.6	225.0	280	442	215	17.5	400	350H8	450
PH70	269.2	255.5	335	457	248	17.5	500	450H8	550
PH80	278.8	280.0	370	481	248	17.5	500	450H8	550

UNIT REF	P	Q	R	T	U1	U2
PH35	225	274	186	130	13	5
PH40	251	321	220	151	19	6
PH50	271	365	250	175	19	6
PH60	329	418	305	200	19	6
PH70	344	458	360	225	24	6
PH80	368	503	360	246	24	6

Input Housing - Reduction

UNIT REF	F	V1	W1	X1	Y1	Z1	TH
PH35							
PH40	28j6	24.0	8P9	60	50	5	M10x22
PH50							
PH60							
PH70	42k6	37.0	12P9	110	110	5	M16x36
PH80							

Output Sleeve

UNIT REF	G	L	LB	V2	W2
PH35	50F7	103	55	53.8	14Js9
PH40	60F7	110	65	64.4	18Js9
PH50	70F7	130	70	74.9	20Js9
PH60	90F7	155	90	95.4	25Js9
PH70	100F7	174	115	106.4	28Js9
PH80	100F7	174	115	106.4	28Js9

Plug-in Output Shaft

UNIT REF	C2	C3	D2
PH35	220	264	45k6
PH40	230	293	55m6
PH50	280	337	65m6
PH60	305	355	75m6
PH70	355	418	85m6
PH80	355	418	95m6

RENOLD PM Series - PH Type - Output Shaft Dimensions

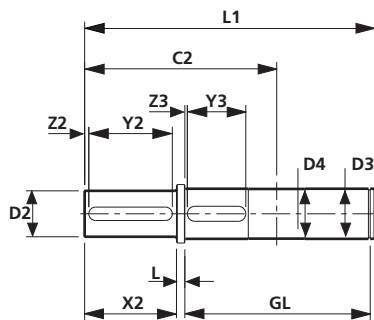

SINGLE EXTENSION PLUG-IN SHAFT

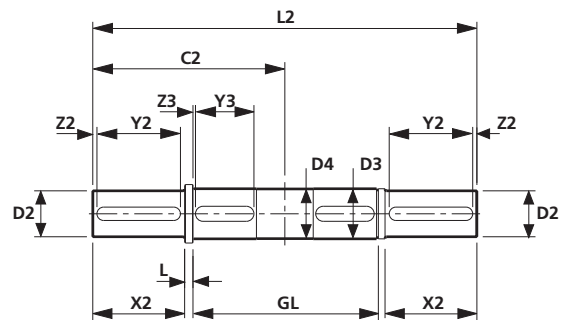

DOUBLE EXTENSION PLUG-IN SHAFT

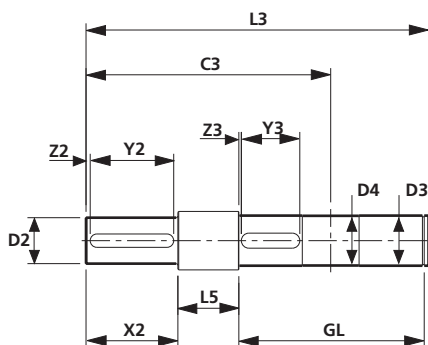

SINGLE EXTENSION PLUG-IN SHAFT - (FLANGED)

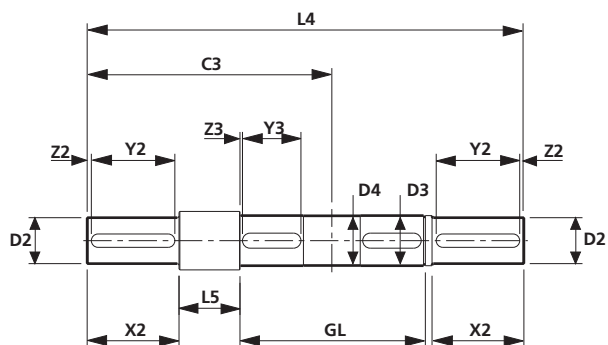

DOUBLE EXTENSION PLUG-IN SHAFT - (FLANGED)

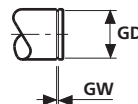
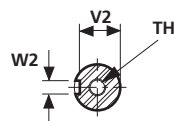

EXTENSION KEYWAY DETAILS CIRCLIP GROOVE DETAILS

Plug-in Shafts

UNIT REF	C2	C3	L	L1	L2	L3	L4	L5	GD	GL	GW
PH35	220	264	7	330.5	440	374.5	484	51	47.00	207.90	2.29
									46.75	207.85	2.15
PH40	230	293	10	347.5	460	410.5	523	73	57.00	222.15	2.29
									56.70	222.10	2.15
PH50	280	337	10	418.5	560	475.5	617	67	67.00	262.65	2.79
									66.70	262.60	2.65
PH60	305	355	10	469.5	610	519.5	660	60	86.50	313.15	3.33
									86.15	313.10	3.15
PH70	355	418	11	538.5	710	601.5	773	74	96.50	351.15	3.33
									96.15	351.10	3.15
PH80	355	418	11	538.5	710	601.5	773	74	96.50	351.15	3.33
									96.15	351.10	3.15

UNIT REF	D2	V2	W2	X2	Y2	Z2	TH	D3	Y3	Z3	D4
PH35	45k6	39.50	14P9	110	100	5	M16x36	50h6	63	3	46
PH40	55m6	49.00	16P9	110	100	5	M20x42	60h6	70	3	56
PH50	65m6	58.00	18P9	140	125	5	M20x42	70h6	90	2	66
PH60	75m6	67.50	20P9	140	125	5	M20x42	90h6	110	3	86
PH70	85m6	76.00	22P9	170	160	5	M20x42	100h6	125	3	96
PH80	95m6	86.00	25P9	170	160	5	M24x50	100h6	125	3	96

RENOLD PM Series - PH Type - Torque Restraint Bracket

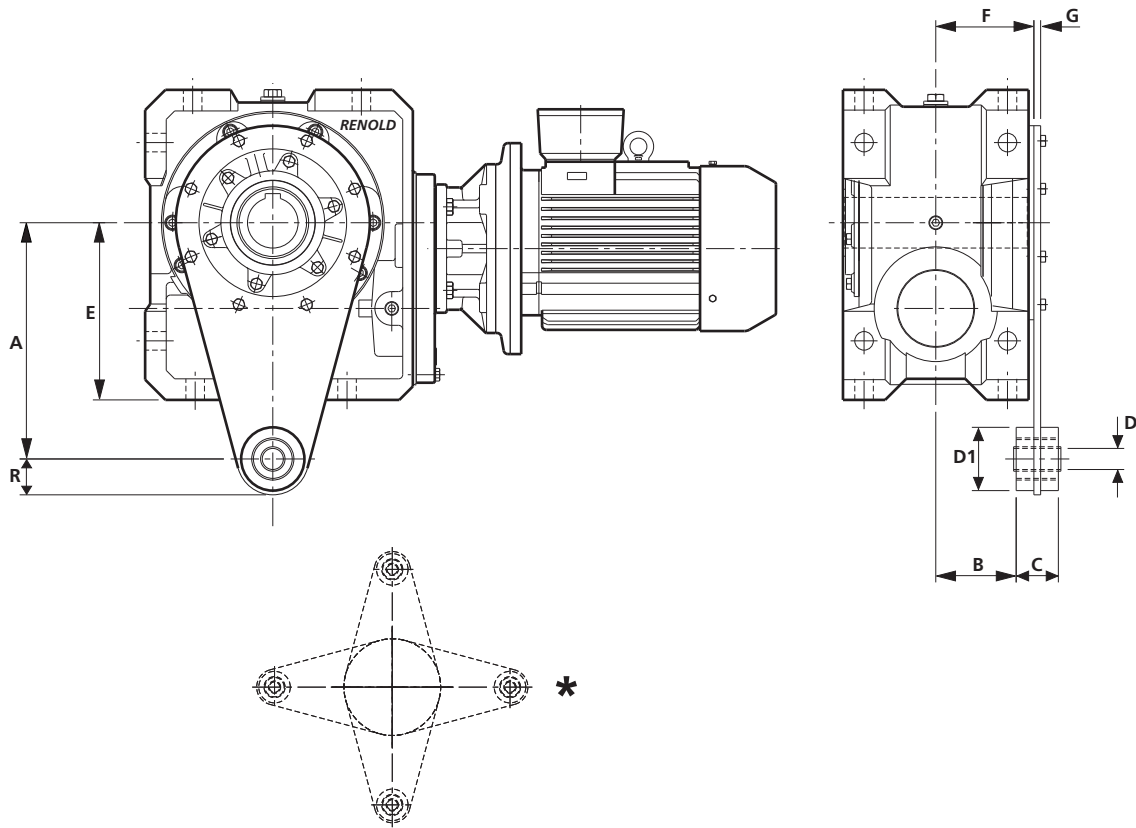

BRACKET CAN BE MOUNTED IN ANY OF 4 POSITIONS SHOWN
- ON EITHER SIDE OF GEAR UNIT

*CHECK THE CLEARANCE ON THE
MOTOR ADAPTOR SIDE WITH RENOLD

Torque Restraint Bracket

UNIT SIZE	A	B	C	D	D1	E	F	G	R
PH35	240	68.0	70	20	70	180	97	12	45
PH40	270	105.0	70	20	70	210	131	12	45
PH50	300	116.0	70	20	70	240	145	12	45
PH60	360	134.5	66	30	80	280	160	15	52
PH70	415	159.5	66	30	80	335	185	15	52
PH80	450	159.5	66	30	80	370	185	15	52

RENOLD PM Series - PH Type - Shrink Disc Dimensions

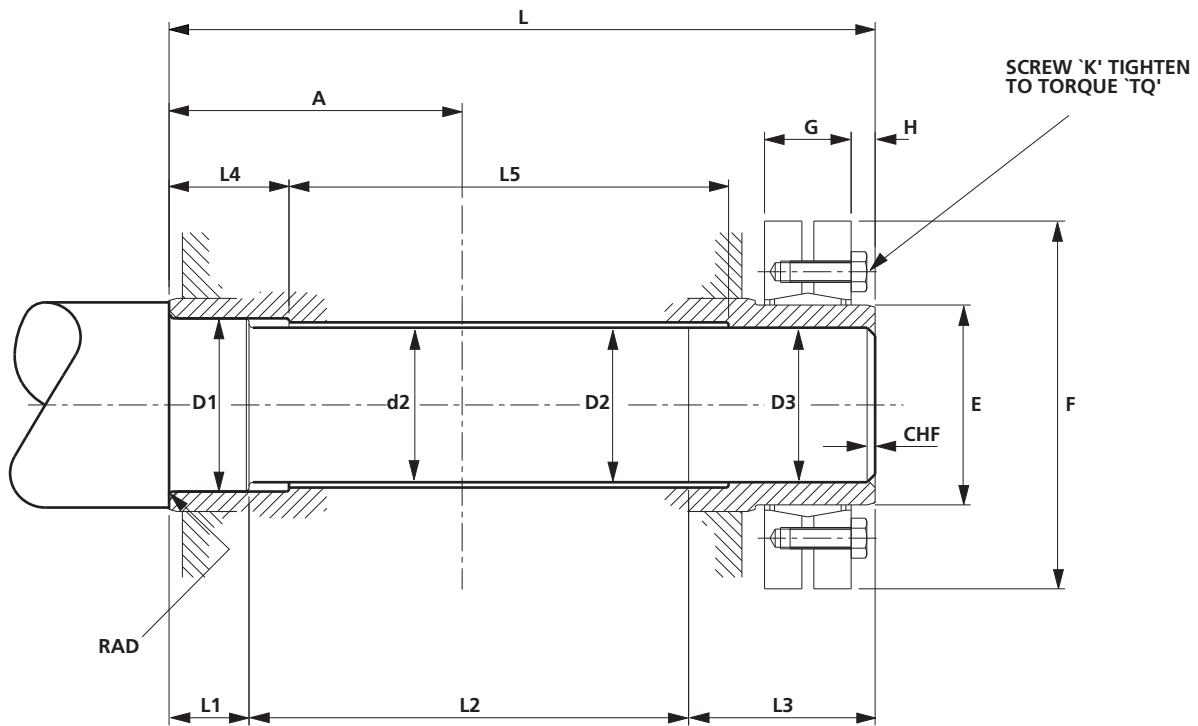

Shrink Disc

UNIT SIZE	Driven Shaft Details							
	D1	D2	D3	L1	L2	L3	RAD	CHF
PH35	52g6	50	50g6	25	140	80	1.5	2
PH40	65g6	60	60g6	30	150	85	1.5	3
PH50	75g6	70	70g6	35	180	95	1.5	3
PH60	90g6	85	85g6	40	220	115	2	3
PH70	100g6	95	95g6	45	250	135	2	3
PH80	100g6	95	95g6	45	250	135	2	3

UNIT SIZE	Hollow Shaft Details						
	A	D1	d2	D3	L	L4	L5
PH35	102.9	52H7	51	50H6	245	35	140
PH40	110	65H7	62	60H6	265	40	150
PH50	130	75H7	72	70H6	310	50	180
PH60	155	90H7	88	85H7	375	55	220
PH70	174	100H7	98	95H7	430	60	250
PH80	174	100H7	98	95H7	430	60	250

UNIT SIZE	Shrink Disc Details							Max. Torque (Nm)
	REF	E	F	G	H	K	TQ (Nm)	
PH35	62-4071	62	110	30.5	6	M6	12	1100
PH40	75-4071	75	138	32.5	9	M8	30	1600
PH50	90-4071	90	155	39	9	M8	30	3000
PH60	110-4071	110	185	50	12	M10	59	5400
PH70	125-4071	125	215	54	23	M10	59	7500
PH80	125-4071	125	215	54	23	M10	59	7500
	125-4091	125	215	65	12	M12	100	10000

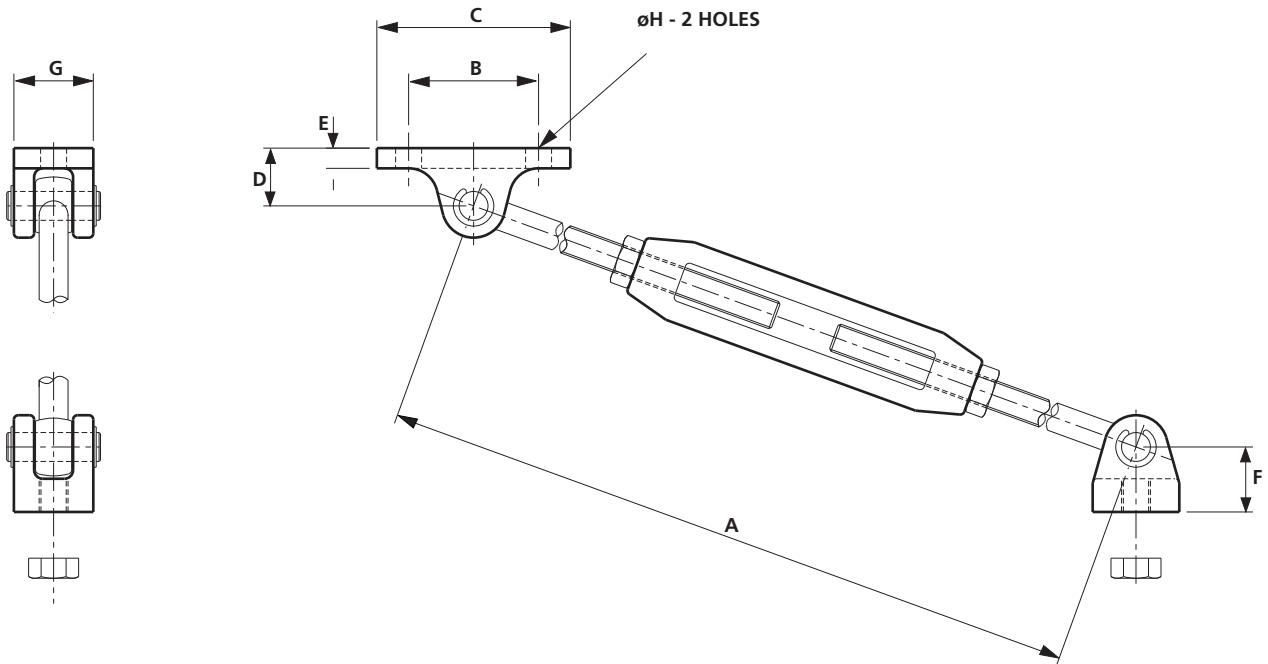

Torque Arm Assembly

UNIT SIZE	A	B	C	D	E	F	G	H
PH35	600	75	108	35	13	40	41	M12
	750							
PH40	600	90	133	40	14	45	52	M16
	750							
PH50	600	90	133	40	14	45	52	M16
	750							
PH60	910	115	178	57	21	55	76	M20
	760							
PH70	910	115	178	57	21	55	76	M20
	760							
PH80	910	115	178	57	21	55	76	M20
	760							

RENOLD PM Series - Installation, Maintenance & Storage**Initial Running**

All units are supplied without oil.

First Filling

When installed and before running, the unit should be filled with new lubricant to the correct level as follows.

With the gear stationary, remove the filler and breather plug and oil level plug. Fill until the lubricant level is visible at the indicator (if fitted) or until lubricant overflows from oil level aperture.

Replace and secure both plugs. Care should be taken to avoid overfilling, as this may cause subsequent leakage.

Starting Up

All units have been subjected to a short test before despatch to the customer but it takes many hours running under full load for the gear to attain its highest efficiency. The gear may if necessary be put to work immediately on full load, but if circumstances permit it is better for the ultimate life of the gear to run it in under gradually increasing load. Attaining the full load after about 20 to 40 hours. Reasonable precautions should however, be taken to avoid overloads in the early stage of running. Temperature rise on the initial run will be higher than that eventually attained after the gear is fully run in.

Routine Maintenance

The oil level in the unit should be regularly maintained, and should be checked at least once a month. To avoid false readings, examination of the oil level should be made with the gear stationary, and to maintain free ventilation of the unit under all conditions, the breather hole in the filler plug should be kept clear at all times.

Changing Oil

The oil should be changed completely at intervals depending upon the working conditions.

Grease Lubrication of Bearings

Where this feature is included, the bearing caps are fitted with a grease nipple or stauffer lubricator, which should be used to lubricate the bearings.

When mounted with wormshafts vertical, the top bearing requires grease lubrication. Standard units, therefore, need to be modified by the inclusion of a grease nipple and nylos ring adjacent to the top bearing. Customers must advise us of this requirement when placing enquiries and orders.

Couplings and Bedplates

All couplings should be carefully fitted and shafts accurately aligned. To prevent damage to the bearings, coupling half-bodies should not be hammered onto shafts.

Worm gear units and other drive components should be rigidly mounted on firm foundations to prevent movement and vibration which may affect the alignment of the shafts. Suitable bedplates can be supplied if required.

Abnormal Ambient Temperatures

If the gear unit is to be operated under extremes of temperature or humidity, special oils may be required and recommendations will be made on request.

Storage

All worm gear units stored or left inactive for long periods should be adequately protected, particularly those on exposed sites and those operating in corrosive atmospheres.

The following precautions will generally be adequate, but advice on the protection of particular units will be given, if required.

If empty of oil: spray the gear case interior with rust preventative oil; compatible with lubricant recommended for service conditions.

If filled with oil: operate at full speed once per month for not less than 10 minutes to ensure liberal coating of all internal parts with oil.

For indefinite storage: completely fill unit with oil ensuring complete submersion of all internal components. Shafts should be occasionally turned by hand. When unit is returned to service, drain and refill with new oil to correct level.

External shaft extensions and oil seals can be protected by the use of grease impregnated tape. Full long term storage specification details can be obtained from Renold on request.

Spare Parts

Information relating to spare parts is available on request.

RENOLD PM Series - PH Type - Lubrication Information

The correct fill of oil for the unit size and mounting position can be found in either the appropriate catalogue or the Installation and Maintenance Guide. Only good quality oils should be used, such as those listed below, as the use of inferior or unsuitable products may cause rapid wear and possible damage to the gearbox. Some EP additives such as Sulphur can attack Bronze especially at operating temperatures above 80°C and therefore should be avoided.

Oils with three viscosity ranges (Light, medium and heavy) are listed below, the correct choice depends on the application, operating speed, load and temperature. Temperature and speed can often be the main factor as it effects the operating viscosity. If the unit runs below the catalogue rating and operates at a temperature below 60°C then a light grade oil should be used. Operating at catalogue rating with temperatures up to 90°C requires medium grade oil and higher temperatures and loading require heavy grade oils. When using POA oils this temperature can be increased by about 5°C.

If the unit is operating with gear speeds below 2.5 m/s (500ft/min) then the next higher grade should be used. Using too heavy a grade than required will result in reduced efficiency, too light a grade will result in premature wear, if in doubt ask Renold Gears Technical Department.

Which Oil to Select

There are three main oils Mineral, Synthetic (Polyalphaolefin) and Synthetic (Polyglycol). Mineral oils tend to be cheaper, have a lower life and are less efficient. Synthetic (Polyalphaolefin) can operate over a higher temperature range, are more efficient, give higher ratings and have a longer life and as such are preferred.

The use of Synthetic (Polyglycol) are not recommended without prior discussion with Renold as special paints and seals are required.

If necessary a list of recommended food grade oils is available on request.

If a Sprag Clutch backstop is fitted internally to the gear unit, oils with EP type additives must not be used.

The oils shown below are all suitable for use with Sprag Clutch backstops.

Mineral Oil	Light		Medium		Heavy	
		Temp°C		Temp°C		Temp°C
Mobil DTE	BB	-7 to 90	AA	2 to 90	HH	2 to 90
Castrol Alpha ZN	220	-9 to 120	320	-9 to 120	460	-9 to 120
Shell Vitrea	220	-24 to 120	320	-18 to 120	460	-15 to 120
Esso Teresso	220	-18 to 120	320	-12 to 120	460	-9 to 120
Kluberoil GEM 1	220	-18 to 100	320	0 to 100	460	0 to 100

Synthetic (Polyalphaolefin)	Light		Medium		Heavy	
		Temp°C		Temp°C		Temp°C
Mobil Gear SHC	630	-42 to 160	632	-42 to 160	634	-39 to 160
Castrol Alpha T	220	-36 to 80	320	-33 to 80	460	-33 to 80
Shell Omala RL	220	-40 to 80	320	-40 to 80	460	-40 to 80
Esso Teresso SHP	220	-42 to 150	320	-36 to 150	460	-30 to 150

RENOLD PM Series - PH Type - Oil Capacities

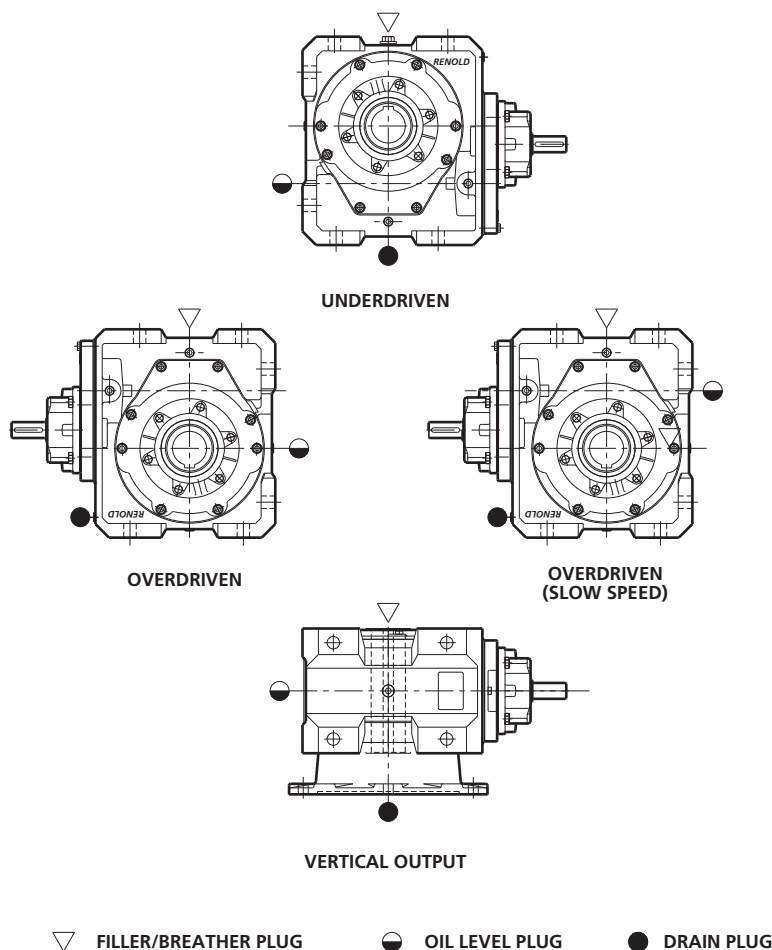

PM Series PH Helical/Worm Oil Quantities (Litres)

UNIT REF	Underdriven	Over driven		Vertical Output -with dry well
		Normal Speed	Slow Speed	
PH35	1.2	2.6	4.0	1.6
PH40	1.8	3.6	7.0	2.9
PH50	3.0	6.6	11.0	5.7
PH60	5.3	10.3	18.0	8.7
PH70	8.1	15.5	27.0	14.5
PH80	10.0	19.0	34.0	18.1

Nominal oil quantity - May vary with ratio

RENOLD PM Series - PH Type - Unit Weights**PM Series PH Single Reduction Weights (kg)**

PH35	Foot Mounting			Flange Mounting			Vertical Output (Dry Well)		
	Hollow Shaft	Single Extension	Double Extension	Hollow Shaft	Single Extension	Double Extension	Hollow Shaft	Single Extension	Double Extension
PH35-Red'n gear	59	64	65	65	70	72	67	72	74
PH35 + MD80K	70	75	76	75	81	82	77	83	84
PH35 + MD80G	71	75	77	76	82	83	78	84	85
PH35 + MD90S	73	78	79	79	84	86	81	86	88
PH35 + MD90L	76	81	82	81	87	88	83	89	90
PH35 + MD100L	83	88	89	88	94	95	90	96	97
PH35 + MD100LX	87	91	93	92	98	99	94	100	101
PH35 + MD112M	93	97	99	98	104	105	100	106	107
PH35 + MD132S	110	114	116	115	121	122	117	123	124
PH35 + MD132M	127	132	133	132	138	139	134	140	141

PH40	Foot Mounting			Flange Mounting			Vertical Output (Dry Well)		
	Hollow Shaft	Single Extension	Double Extension	Hollow Shaft	Single Extension	Double Extension	Hollow Shaft	Single Extension	Double Extension
PH40-Red'n gear	82	90	92	94	103	105	95	104	106
PH40 + MD80K	93	100	109	104	113	115	106	115	117
PH40 + MD80G	94	101	110	105	114	116	106	115	117
PH40 + MD90S	96	104	113	108	117	119	109	118	120
PH40 + MD90L	99	106	115	110	119	121	112	121	123
PH40 + MD100L	106	113	122	117	126	128	119	128	130
PH40 + MD100LX	110	117	126	121	130	132	122	131	134
PH40 + MD112M	116	123	132	127	136	138	128	137	140
PH40 + MD132S	133	140	149	144	153	155	145	154	156
PH40 + MD132M	150	157	166	161	170	172	163	172	174

PH50	Foot Mounting			Flange Mounting			Vertical Output (Dry Well)		
	Hollow Shaft	Single Extension	Double Extension	Hollow Shaft	Single Extension	Double Extension	Hollow Shaft	Single Extension	Double Extension
PH50-Red'n gear	118	129	133	131	145	149	133	147	151
PH50 + MD80K	128	140	144	142	156	159	143	158	161
PH50 + MD80G	129	141	144	142	156	160	144	158	162
PH50 + MD90S	132	143	147	145	159	163	147	161	165
PH50 + MD90L	134	146	150	148	162	166	150	164	167
PH50 + MD100L	141	153	157	155	169	172	157	171	174
PH50 + MD100LX	145	157	160	159	173	176	160	174	178
PH50 + MD112M	151	163	166	165	179	182	166	180	184
PH50 + MD132S	168	180	183	181	195	199	183	197	201
PH50 + MD132M	185	197	201	199	213	217	201	215	218
PH50 + MD160M	246	258	262	260	274	278	262	276	280
PH50 + MD160L	266	278	282	280	294	298	282	296	300

RENOLD PM Series - PH Type - Unit Weights

PH60	Foot Mounting			Flange Mounting			Vertical Output (Dry Well)		
	Hollow Shaft	Single Extension	Double Extension	Hollow Shaft	Single Extension	Double Extension	Hollow Shaft	Single Extension	Double Extension
PH60-Red'n gear	190	211	216	207	231	236	211	235	240
PH60 + MD100L	212	233	237	228	253	258	232	256	261
PH60 + MD100LX	215	236	241	232	256	261	236	260	265
PH60 + MD112M	221	242	247	238	262	267	242	266	271
PH60 + MD132S	240	261	266	257	282	286	261	285	290
PH60 + MD132M	258	279	284	275	299	304	278	303	308
PH60 + MD160M	312	333	338	329	353	358	333	357	362
PH60 + MD160L	332	353	358	349	373	378	353	377	382
PH60 + MD180M	366	387	392	383	407	412	387	411	416
PH60 + MD180L	380	401	406	397	421	426	401	425	430

PH70	Foot Mounting			Flange Mounting			Vertical Output (Dry Well)		
	Hollow Shaft	Single Extension	Double Extension	Hollow Shaft	Single Extension	Double Extension	Hollow Shaft	Single Extension	Double Extension
PH70-Red'n gear	266	296	303	292	327	335	298	333	340
PH70 + MD100L	287	317	325	313	348	356	319	354	362
PH70 + MD100LX	291	321	329	317	352	360	323	358	366
PH70 + MD112M	297	327	335	323	358	366	329	364	372
PH70 + MD132S	316	346	354	342	377	385	348	383	391
PH70 + MD132M	334	364	371	360	395	402	366	401	408
PH70 + MD160M	388	418	426	414	449	457	420	455	463
PH70 + MD160L	408	438	446	434	469	477	440	475	483
PH70 + MD180M	442	472	480	468	503	511	474	509	517
PH70 + MD180L	456	486	494	482	517	525	488	523	531
PH70 + MD200L	508	538	546	534	569	577	540	575	583

PH80	Foot Mounting			Flange Mounting			Vertical Output (Dry Well)		
	Hollow Shaft	Single Extension	Double Extension	Hollow Shaft	Single Extension	Double Extension	Hollow Shaft	Single Extension	Double Extension
PH80-Red'n gear	308	338	346	338	375	385	344	381	390
PH80 + MD100L	330	360	367	360	397	406	366	402	412
PH80 + MD100LX	333	363	371	364	401	410	369	406	416
PH80 + MD112M	339	369	377	370	407	416	375	412	422
PH80 + MD132S	359	388	396	389	426	435	394	431	441
PH80 + MD132M	376	406	414	406	443	453	412	449	458
PH80 + MD160M	430	460	468	461	498	507	466	503	513
PH80 + MD160L	450	480	488	481	518	527	486	523	533
PH80 + MD180M	484	514	522	515	552	561	520	557	567
PH80 + MD180L	498	528	536	529	566	575	534	571	581
PH80 + MD200L	551	581	588	581	618	627	586	623	633

Notes

ARGENTINA

Bennett Anderson,
Gonzales Y Cia SA, J.Aguero 1817
(1605) Munro
Buenos Aires
Tel: + 54 11 4761 5007/ 3531
Fax: + 54 11 4760 0866

Los Ases Ketten SA,
Avda Gaona 4046,
1407 Buenos Aires
Tel: + 54 116710855
Fax: + 54 116713141

AUSTRALIA

Renold Australia Proprietary Ltd
508-520 Wellington Road,
Mulgrave, Victoria 3170, Mulgrave
North
Tel: +61 (0) 3 9262 3333
Fax: +61 (0) 3 9561 8561
Branch Tel: +61 (0) 3 9262 3355
Email: melcag@renold.com.au

Unit 1,
12-18 Victoria Street, Lidcombe,
Sydney, NSW 2141.
Tel: +61 (0) 2 9649 3122
Fax: +61 (0) 2 9646 1295
Email: nswsales@renold.com.au

Unit 10,
31 Boyland Avenue,
Coopers Plains, Brisbane,
Queensland 4108.
Tel: +61 (0) 7 3275 2155
Fax: +61 (0) 7 3875 1779

Corner Orsmond & George Sts.
Hindmarsh, Adelaide,
South Australia 5007.
Tel: +61 (0) 8 8346 9077
Fax: +61 (0) 8 8340 1217

Unit 2,
127 Grandstand Street, Belmont,
Perth, West Australia 6104.
Tel: +61 (0) 8 9479 1388
Fax: +61 (0) 8 9479 1364

Unit 13
56 Industrial Drive,
Mayfield, NSW 2304
Tel: +61 (0) 2 4960 8440
Fax: +61 (0) 2 4960 8455

PO Box 159,
Unanderra, Wollongong, NSW 2526.
Tel: +61 (0) 2 42 621771
Fax: +61 (0) 2 42 621772

Shop B,
247 Ingham Road,
Garbutt, Townsville, QLD 4814.
Tel: +61 (0) 7 4779 5922
Fax: +61 (0) 7 4775 1446

AUSTRIA

Renold GmbH (Lageplan)
Rudolf Hausner Gasse 6
1220 Wien
Austria.
Tel: +43 (0) 1 3303484 0
Fax: +43 (0) 1 3303484 5
Email: office@renold.at

BANGLADESH

Brady & Co (Bangladesh) Ltd,
31, Bangabandhu Avenue,
Dhaka-1000
Tel: + 880 2802358
Fax: + 880 2802358

BELGIUM

Renold Continental Ltd
Allée Verte 1,1000 Brussel.
Tel: +32 (0) 2 2011262
Fax: +32 (0) 2 2032210
Email: info@renold.be

CANADA

Renold Canada Ltd
121 Roy Boulevard, Brantford,
Ontario, N3T 5N4
Toll Free: 1-800-265-9970
Tel: +1 519 756 6118
Fax: +1 519 756 1767
Email: inquiry@renoldcanada.com

622 rue De Hull,
Ville La Salle,
Quebec, H8R 1V9.
Toll Free: 1-800-361-1414
Tel: +1 514 367 1764
Fax: +1 514 367 4993

CHILE

Sargent S.A.,
Avda. Presidente Bulnes No 205,
Casilla 166-D,
Santiago - Chile.
Tel: (56 2) 510 3000
Fax: (56 2) 698 3989
Email: secventas@sargentagricola.cl

CHINA

Renold Transmission (Shanghai)
Company Limited
Unit 4A, Block 15
69 XiYa Road
Waigaoqiao Free Trade Zone
Shanghai 200131
Tel: +86 21 5046 2696
Fax: +86 21 5046 2695
Email: sales@renold.cn

COLOMBIA

Transmission de Potencia SA
Carrera 68B No10 - 98
Apartado Aereo 6794
Santafe de Bogato DC
Tel: + 571 2600100
Fax: + 571 2904823

Importadora Casa Sueca Ltda.,
Calle 52, No. 1N-74,
Apartado Aereo 1208, Cali.
Tel: 00 57 2346 4455
Fax: 00 57 2346 4967

CZECH REPUBLIC

Renold GesmbH
Technical Office, Dipl. Ing. R.
Badura,
Jaroslavice 129, CZ-76001 Zlin.
Tel: +42 67 7211074
Fax: +42 67 7211074

DENMARK

Renold A/S,
Skelmarksvej 6, Postboks 90,
2605 Brøndby.
Tel: +45 43 452611
Fax: +45 43 456592
Email: infor@renold.com

EGYPT

Itaco,
Int'l for Trading & Agency,
P.O. Box 7550, Nasr City, Cairo.
Tel: + 20 2 2718036
Fax: + 20 2 2878089

EL SALVADOR

MVA & Cia
Residencial San Luis,
Avenida 4 #45 Block 2,
San Salvador,
El-Salvador, Central America
Tel: + 503 274 649

FINLAND

Kraftmek Oy,
Hitsaajankatu 9, P.O. Box 36,
FIN-00811 Helsinki
Tel: + 358 9 7557355
Fax: + 358 9 7550414

FRANCE

Brampton Renold,
Zone Industrielle A, Rue de la
Pointe, BP 359, 59473 Seclin Cedex.
Tel: +33 (0) 320 16 29 29
Fax: +33 (0) 320 16 29 00

GERMANY

Arnold & Stolzenberg,
Juliusmühle,
D37574 Einbeck.
Postal address:
PO Box 1635 + 1645
D37557 Einbeck.
Tel: +49 (0) 5562 81163
Fax: +49 (0) 5562 81102
Email: arnoldandstolzenberg
@t-online.de

GREECE

Provatas Engineering
53/47 Dragatsaniou St,
185 - 45 Piraeus.
Tel: + 30 1 4170266
Fax + 30 1 4170253

HOLLAND

Renold Continental Ltd,
Jarmuiden 30c,
1046 AD Amsterdam.
Tel: +31 (0) 20 614 6661
Fax: +31 (0) 20 614 6391
Email: info@renold.nl

HUNGARY

Renold GesmbH
Technical Office, Ing. Havasi Janos,
Ret Utca 25, H-6200 Kiskörös.
Tel: +36 (0) 78 312483
Fax: +36 (0) 78 312484

INDIA

Voltas Limited.,
Machine Tool Division,
Voltas House B, 3rd Floor,
TB Kadam Marg,
Chinchpokli,
Mumbai 400033
Tel: 091 22 370 0829
Fax: 091 22 371 4889
Email: mshaik@voltasltd.com

NORTHERN IRELAND

Henry R. Ayton Ltd,
Derrriaghy, Dunmurry, Belfast.
Tel: 01232 618511
Fax: 01232 602436

IRELAND

E. Fox
Adelaide House
Baldonnell Business Park
Dublin 22
Tel + 353 (0) 1 4693500
Fax + 353 (0) 1 4693555

ISRAEL

Technica J. Bokstein Co. Ltd,
3 Hatrupa Street,
Netanya 42504
Tel: + 972 9 8850505
Fax: + 972 36131074

ITALY

Bianchi Cuscinetti SpA
Via Zuretti, 102, 20125 Milano,
Tel: + 39 02 67861
Fax: + 39 02 66981669

JAMAICA

Masterton Ltd,
21-25 Hanover Street, P.O. Box 73
Kingston.
Tel: + 18 767 540557
Fax: + 18 769 227807

KOREA

S.S. Corporation,
Yeouido, P.O. Box 60, Seoul.
Tel: 00-822-783-6829
Fax: 00-822-784-9322
Email: sslcorp@chollian.net

MALAYSIA

Renold (Malaysia)
LOT 2, Jalan Kecapi 33/2,
Eiite Industrial Park,
Off Jalan Bukit, Kemuning,
40400 Shah Alam, Selangor,
Malaysia.
Tel: + 60 3 5122 9880
Fax: + 60 3 5191 9881
Email: malaysia@renold.com

201, Jalan Simbang,
Taman Perling,
81200 Joho Bharu, Johor, Malaysia.
Tel: + 60 (0) 7 2384152-3
Fax: + 60 (0) 7 2384155
Email: malaysia@renold.com

67A, Jalan Medan Ipoh 6,
Bandar Baru Medan,
31400 Ipoh, Perak
Tel: + 60 (0) 5 548 0059
Fax: + 60 (0) 5 548 0214
Email: malaysia@renold.com

28B Jalan Perai Jaya 3,
Bandar Perai Jaya, 13600 Perai,
Penang, Malaysia
Tel: + 604-399 9648
Tel: + 604-399 0648
Fax: + 604-399 5649
Email: malaysia@renold.com

MAURITIUS

Dynamotors Ltd,
P.O. Box 733, Bell Village,
Tel: + 230 2122847/8/9
Fax: + 230 2088348

MEXICO

**Accesorios Automotrices y
Rodamientos Industriales,
S.A. de C.V., Calz Legaria 833-A
Col Irigacion, Mexico DF 11500
Tel: + 52 5 395 6300
Fax: + 52 5 395 6370**

RENOLD Worldwide Sales and Services**NEW ZEALAND**

Renold New Zealand,
594 Rosebank Road,
Avondale, Auckland.

Postal Address:
PO Box 19460,
Avondale, Auckland.
Tel: + 64 (0) 9 828 5018
Fax: + 64 (0) 9 828 5019
Email: aksales@renold.co.nz

Christchurch Branch Office,
32 Birmingham Drive, Christchurch,
PO Box 9006, Christchurch,
Tel: + 64 03 338 2169
Fax: + 64 03 338 8663

NORWAY

G. Heier A/S,
Postal Address: Postboks 6615,
Rodelokka, 0502 Oslo, Norway.
Office Address: Thv, Meyersgt.
7, Oslo.
Tel: + 47 232 34230
Fax: + 47 232 34242

PAKISTAN

Brady & Co. of Pakistan Ltd,
Shernaz House, P.O. Box 4453,
West Wharf Road, Karachi 2.
Tel: + 92 21.2310367/201712
Fax: + 92 21.2313376/2313378

PERU

Corporacion Basco S.A.C.
Av. Argentina 1165,
Lima 1, RUC 25776186.
Tel: + 51 1 4336633
Fax: + 51 1 4313188

PORTUGAL

Harker, Sumner, S.A.
Zona Industrial Maia 1 - Sector X
4475 - 132 Gemunde - Maia
Portugal.
Tel: + 351 229 4478 090
Fax: + 351 229 4478 098
E-mail: accionamantos.ind@harker.pt

SINGAPORE

Renold Transmission Limited
63 Hillview Avenue, #07-13,
Lam Soon Industrial Building,
Singapore 669569.
Tel: + 65 6760 2422
Fax: + 65 6760 1507
E-mail: renold@mbox5.singnet.com.sg

SOUTH AFRICA

Renold Croft (Pty) Limited,
Corner Liverpool and Bolton Streets,
Nestadt Industrial Sites, Benoni, 1501
Postal Address: Private Bag x 030,
Benoni, 1500.
Tel: + 27 (0) 11 747 9500
Fax: + 27 (0) 11 747 9505
E-mail: renold@iafrica.com

P.O. Box 2661, Witbank 1035,
Mpumalanga,
Republic of South Africa.
Tel: +27 (0) 13 692 7760
Fax: +27 (0) 13 697 0546
Email: renoldwit@worldonline.co.za

SPAIN

Brown Pestell,
Ctra N-11 Lm. 599.5 Nave 5,
08780 Palleja, Barcelona.
Tel: + 34 93 6630740
Fax: + 34 93 6632057

SWEDEN

Renold A/S
Skelmarksvej 6, Postboks 90
2605 Brøndby
Denmark.
Tel: + 45 43 452611
Fax: + 45 43 456592
E-mail: infor@renold.com

SWITZERLAND

Renold (Switzerland) GmbH,
Ringstrasse 16, Postfach 1115
CH-8600 Dübendorf 1.
Tel: + 41 (0) 44 824 8484
Fax: + 41 (0) 44 824 8411
E-mail: dubendorf@renold.com

THAILAND

Route De Prilly 25,
CH-1023 Crissier.
Tel: + 41 (0) 21 632 9460
Fax: + 41 (0) 21 632 9475
E-mail: crissier@renold.com

THAILAND

United Power Engineering Co Ltd
4 Soi Sukhumvit 81 (Siripot)
Sukhumvit Road
Bangjak, Phrakhanong
Bangkok 10260.
Tel: + 66 2 7425366
Fax: + 66 2 7425379

TRINIDAD

Tracmac Engineering Ltd,
P.O. Box 945, Port of Spain,
Trinidad, West Indies.
Tel: + 1 665 460 1532
Fax: + 1 868 671 0012

TURKEY

Glengo Ithalat Ihracat Mumessillik
AS,
Gungoren Cad. No. 35 Bagcilar,
34560
Bakirkoy, Istanbul.
Tel: + 90 212 4613970
Fax: + 90 212 4613972
www.glengo.com.tr

UNITED KINGDOM

Renold Gears
Holroyd Gears Works, Milnrow,
Rochdale OL16 3LS
Tel: +44 (0) 1706 751000
Fax: +44 (0) 1706 751001
E-mail: gears.sales@renold.com
Web: www.renold.com

Renold Clutches & Couplings

Wentloog Corporate Park,
Newlands Road,
Cardiff CF3 2EU, Wales
Tel: + 44 (0) 29 20792737
Fax: + 44 (0) 29 20793004
(Sales):+ 44 (0) 29 20791360
E-mail: couplings@cc.renold.com
Web: www.renold.com

Renold Hi-Tec Couplings

112 Parkinson Road
Halifax HX1 3QH
Tel: +44 (0) 1422 255000
Fax: +44 (0) 1422 320273
E-mail: sales@hitec.renold.com
Web: www.renold.com

Renold Chain

UK Sales, Horninglow Road,
Burton upon Trent,
Staffordshire, DE14 2PS.
Tel: +44 (0) 1283 512 940
Fax: +44 (0) 1283 512 628
E-mail: enquiry@renold.com

USA

Renold Inc
Bourne Street, PO Box A, Westfield,
New York, 14787-0546
Tel: + 1 716 326 3121
Fax: + 1 716 326 6121
E-mail: renold@cecomet.net

VENEZUELA

Equipos Y Accesorios Astral CA,
Apartado 1651 Valencia.
Tel: + 584 1 332042
Fax: + 584 1 345641

WEB

www.renold.com

Terms and Conditions

- In the interests of safety, customers are reminded that when purchasing any technical product for use at work (or otherwise), any additional or up-to-date information and guidance, which it has not been possible to include in the publication, should be obtained by you from your local sales office in relation to the suitability and the safe and proper use of the product. All relevant information and guidance must be passed on by you to the person engaged in, or likely to be affected by or responsible for the use of the product
- The performance levels and tolerances of our product stated in this catalogue (including without limitation, serviceability, wearlife, resistance to fatigue, corrosion protection) have been verified in a programme of testing and quality control in accordance with Renold, independent and/or international standard recommendations. No representations or warranties are given that our product shall meet the stated performance levels or tolerances for any given application outside the performance levels and tolerances for the product's own specific application and environment.

- Whilst all reasonable care in compiling the information contained in this catalogue is taken, no responsibility is accepted for errors.
 - All information contained in this catalogue is subject to change without notice.
 - The illustrations used in this catalogue represent the type of product described but the goods supplied may vary in some detail from those illustrated.
 - The right is reserved to make modifications to the product to meet manufacturing conditions and/or developments (for example in design or materials).
 - Product can be supplied by Renold companies or representatives around the world on the standard terms and conditions of sale of the company or representative from which the product is purchased.
 - Copyright Renold Power Transmission Limited 2001. All rights reserved.
- Nothing contained in this publication shall constitute a part of any contract, express or implied.

AUSTRALIA

Melbourne (Victoria)
Tel + 61 (03) 9262 3333
Fax + 61 (03) 9561 8561
also at: Sydney, Brisbane, Adelaide, Perth,
Newcastle, Wollongong, Townsville.

AUSTRIA

Vienna
Tel + 43 (0) 13303484-0
Fax + 43 (0) 13303484-5
also at: Kiskörös (Hungary), Jaroslavice
(Czech Republic).

BELGIUM

Brussels
Tel + 32 (0) 2 201 1262
Fax + 32 (0) 2 203 2210

CANADA

Brantford (Ontario)
Tel + 1 519 756 6118
Fax + 1 519 756 1767
also at: Montreal.

CHINA

Shanghai
Tel + 21 5046 2696
Fax + 21 5046 2695

DENMARK

Brøndby (Copenhagen)
Tel + 45 43 45 26 11
Fax + 45 43 45 65 92

FRANCE

Seclin
Tel + 33 (0) 320 16 29 29
Fax + 33 (0) 320 16 29 00

GERMANY

Einbeck
Tel + 49 (0) 5562 81163
Fax +49 (0) 5562 81102
also at: Bielefeld, Düsseldorf,
Kornwestheim.

KOREA

Seoul
Tel + 822 783 6829
Fax +822 784 9322

MALAYSIA

Selangor Darul Ehsan
Tel + 60 3-5191 9880
Fax + 60 3-5191 9881
also at: Johor Bharu, Ipoh, Penang.

NETHERLANDS

Amsterdam
Tel + 31 206 146661
Fax + 31 206 146391

NEW ZEALAND

Auckland
Tel + 64 9 828 5018
Fax + 64 9 828 5019
also at: Christchurch.

SINGAPORE

Singapore
Tel + 65 6760 2422
Fax + 65 6760 1507

SOUTH AFRICA

Benoni
Tel + 27 11 747 9500
Fax + 27 11 747 9505
also at: Witbank.

SWEDEN

Brøndby (Copenhagen)
Tel + 45 43 45 26 11
Fax + 45 43 45 65 92

SWITZERLAND

Dübendorf (Zürich)
Tel + 41 (0) 44 824 84 84
Fax + 41 (0) 44 824 84 11
also at: Crissier (Lausanne).

UK

Renold Gears, Rochdale
Tel + 44 (0) 1706 751000
Fax + 44 (0) 1706 751001
e-mail : gears.sales@renold.com

USA

Westfield NY
Tel + 1 716 326 3121
Fax + 1 716 326 6121

WEB

www.renold.com

E-MAIL

e-mail : gears.sales@renold.com

For other country distributors
please contact Renold UK.

CATPH/09/07

RENOLD
Superior Gear Technology

www.renold.com